

Axiom Canopies

Installation Guides



Contents

Material

- // Extruded aluminium profiles
- // Axiom C is made from extruded aluminium, offers better registration, handling capability and finished appearance compared with standard cold-rolled steel

Surface finish

- // Polyester powder coated
- // Global white

Warranty

- // For more information, please see our website

Axiom C Canopy

Installation Guide



01 Preparation

Axiom C Canopy Components

Item No.	Description
55 14 11 G	Axiom C Canopy Profile
C 3000 H	C Channel 19 x 38mm
A WDN 21 H	T-bar hanger
A 345 G	Axiom Vector MicroLook Tegular Profile corner post
A 348 G	Channel Bracket for Canopy (Aircraft cable included in the kit)
CA 97 H	Clamp for C channel
A 347 G	24mm XL ² connector clip
A 346 G	15mm XL ² connector clip
A 339 J	Axiom Universal T-bar connector clip for cut tees with screws

Axiom C Canopy is a modular suspension system supplied kit with ready-to-assemble components (partly listed above).

Initial Recommendations

- ✔ Axiom C Canopies should always be installed in accordance with all applicable building codes and regulations.
- ✔ Axiom C Canopies, as any other architectural feature located in the ceiling plane, may obstruct or skew the existing or planned fire sprinkler distribution pattern or even delay the activation of the fire detection system. Designers and installers are advised to consult a fire protection engineer for guidance on the proper installation techniques where fire detection or suppression systems are present.
- ✔ Any additional load (such as light spots) **MUST NOT** be suspended from the canopy but independently from the soffit.
- ✔ Axiom C Canopies should be always installed on a horizontal plane.
- ✔ Axiom C Canopies are only suitable for indoor applications.
- ✔ Axiom C Canopies can reach a significant weight. In order to minimise the risk of injuries, the canopies should be installed by a minimum of 2 people.
- ✔ Suspension elements such as threaded rods, anchors or any other element not included in the kit must be chosen to ensure a safe installation and follow local regulations.
- ✔ It is recommended to assemble the canopy under the final ceiling location to avoid later movement.

Gloves supplied in the kit are used to prevent marking the components during installation. They are **NOT** meant to be used as safety gloves.

01 Preparation

Suspension Points

Suspension points should be determined before installing the canopy.

See the recommended suspension point matrix on the last page of this guide.

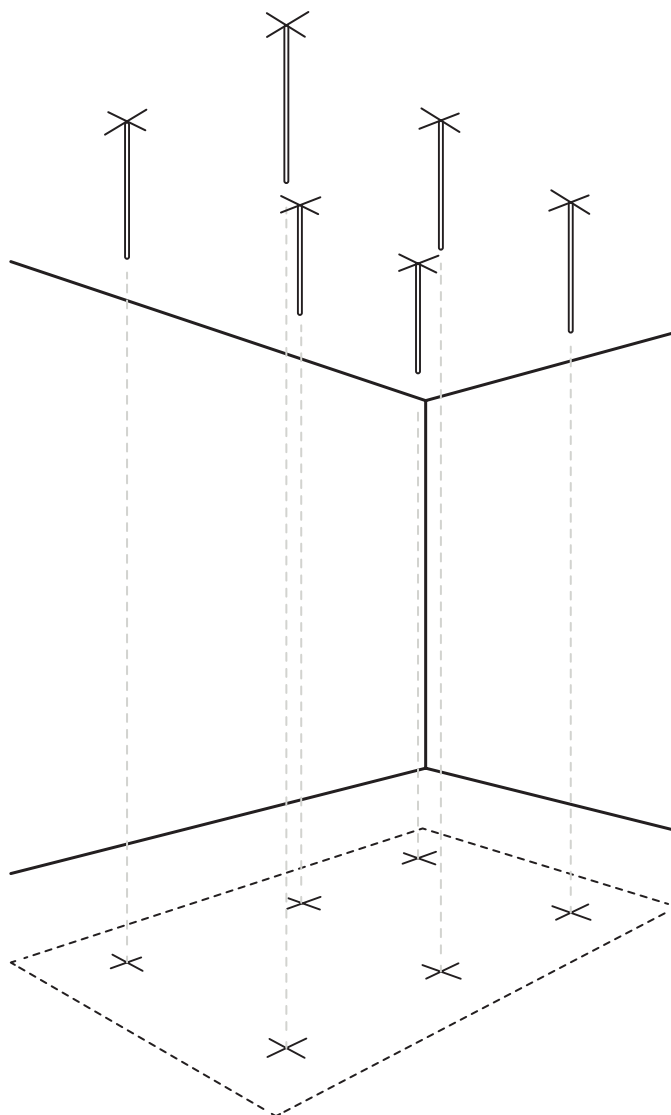

1.8 x 3m module

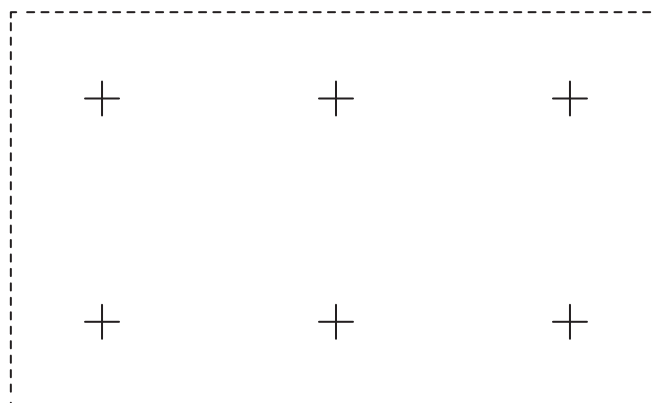

02 The Chassis on the floor

Axiom C Canopy 55 14 11 G

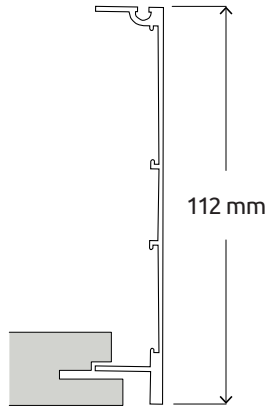

Vector

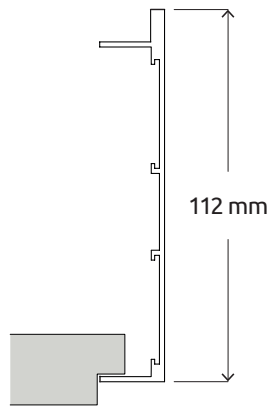

MicroLook

The 1.8 x 3.0m module is used as an example only



4 Axiom profiles / 4 corner posts

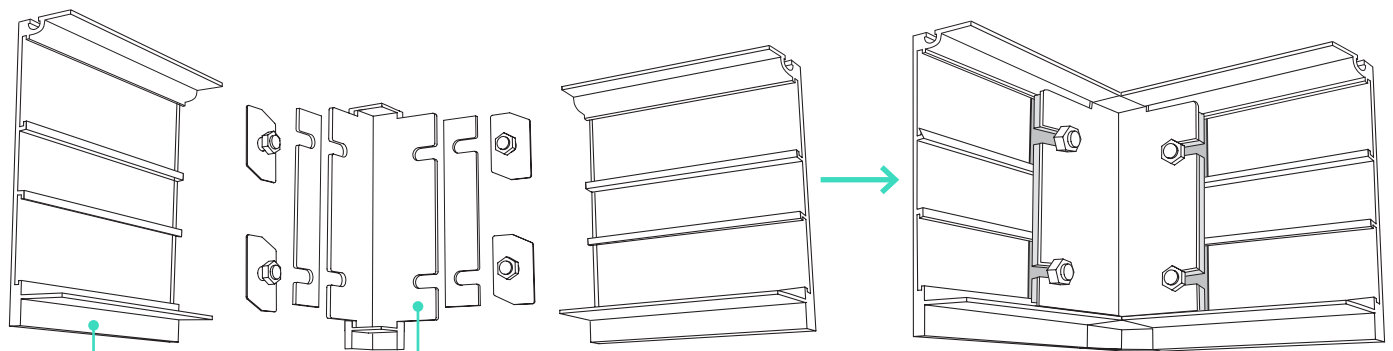

Axiom Profile

Corner Post A 345 G

03 The Primary Grid

on the floor

The 1.8 x 3.0m module is used as an example only

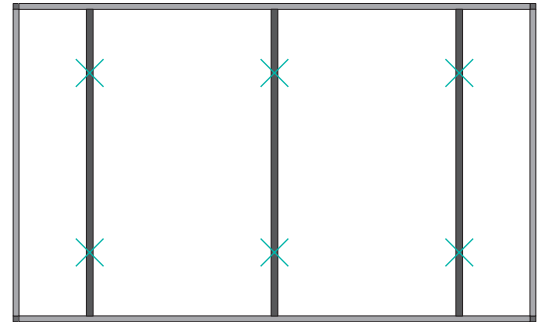

3 C Channels / 6 Universal T-bar connector clips

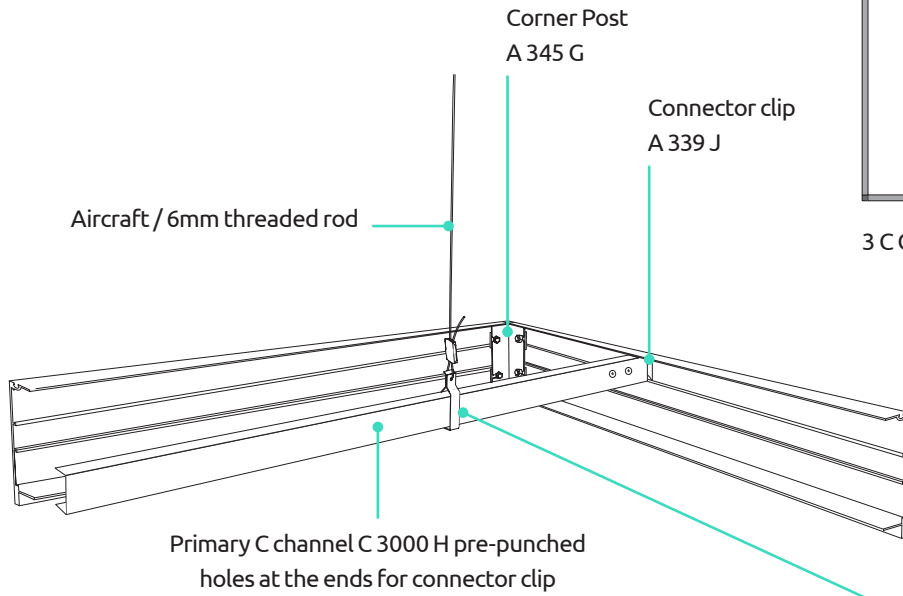

Suspension options

1 Axiom Universal T-bar connector clip A 339 J

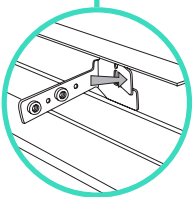
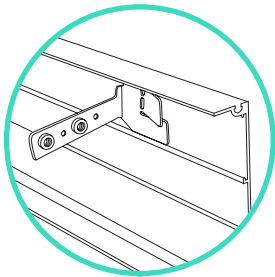

2

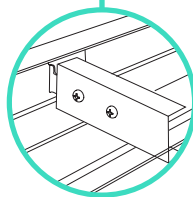
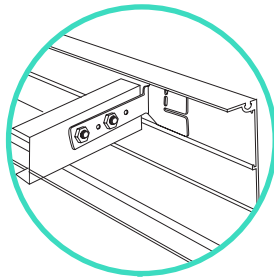

3

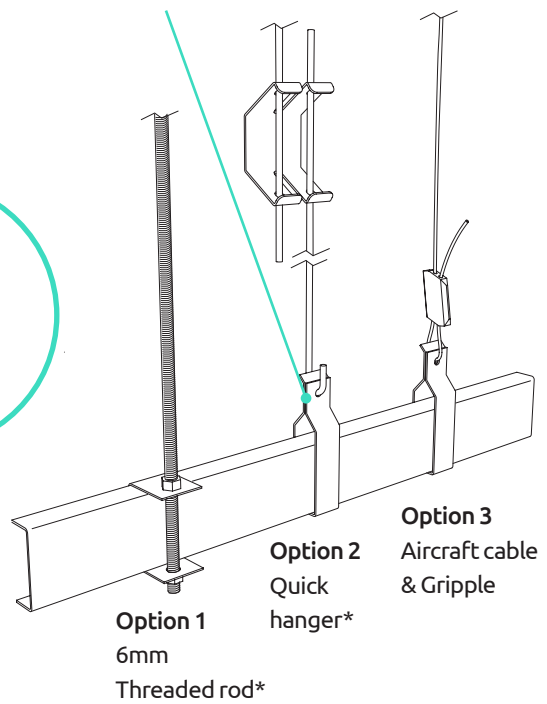
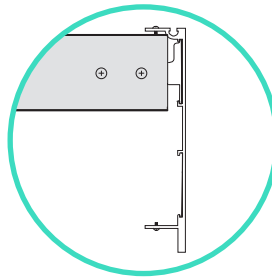

Option 1
6mm
Threaded rod*

Option 2
Quick
hanger*

Option 3
Aircraft cable
& Grapple

*not included in the kit

04 The Grid – Main Runner in the air

The 1.8 x 3.0m module is used as an example only

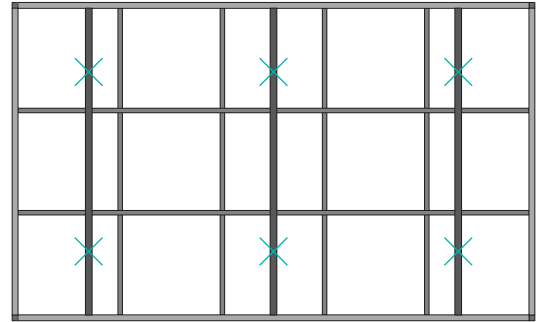

- 2 x Main runners
- 12 x XL² Cross tees
- 10 x Universal T-bar connector clips
- 8 x XL² Cross tee connector clips
- 6 x Clamps for C channel
- Set of screws
- 6 x Channel brackets
- 6 x T-bar hangers

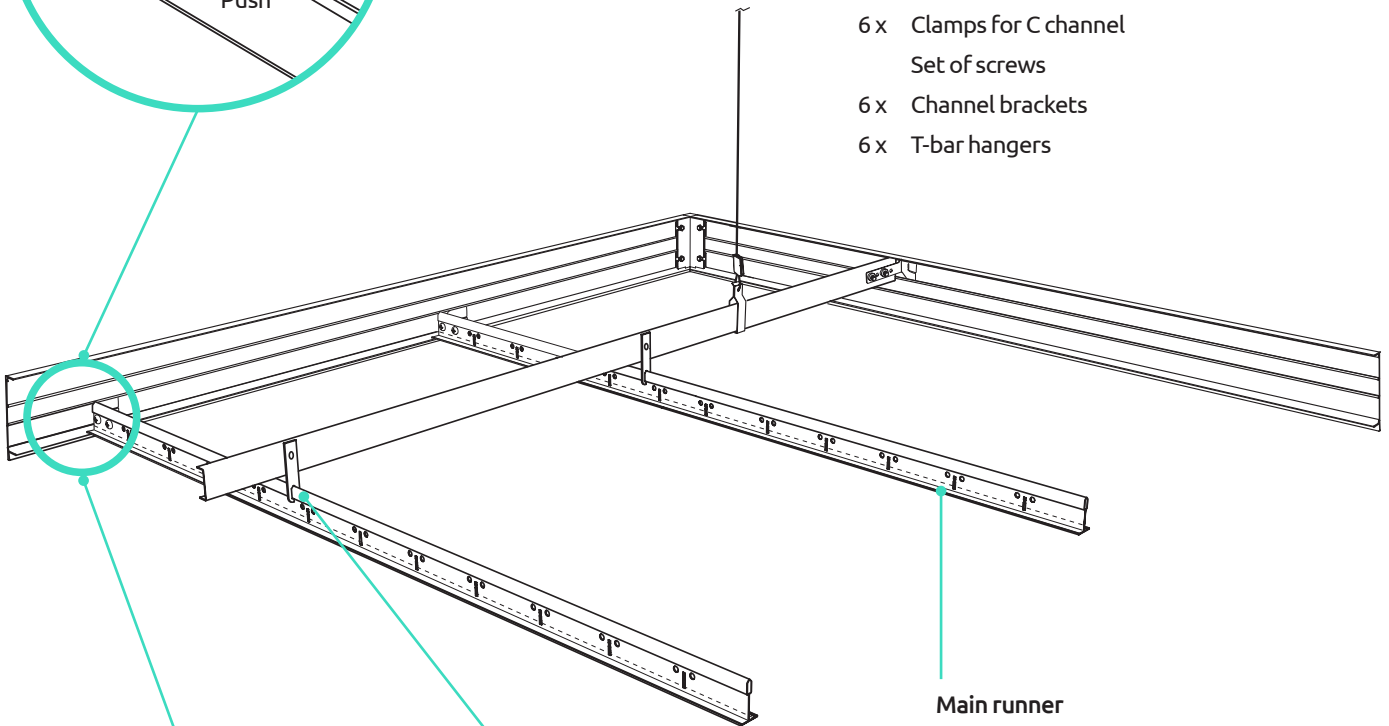
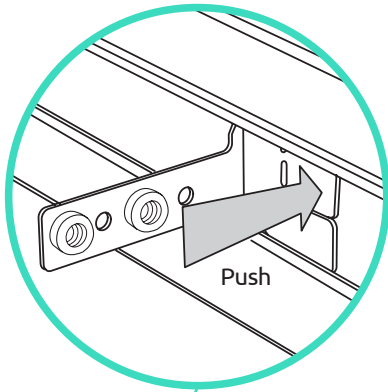

Main runner
Pre cut according to cloud size
Pre-punched holes at the end of alignment
with Universal T-bar connector clip

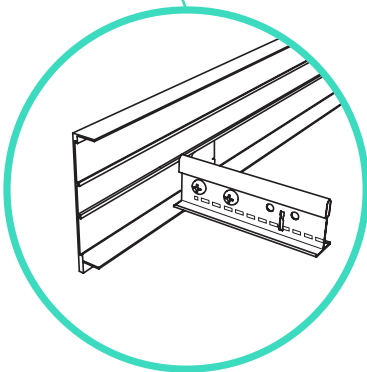

Universal T-bar connector
clip A 339 J

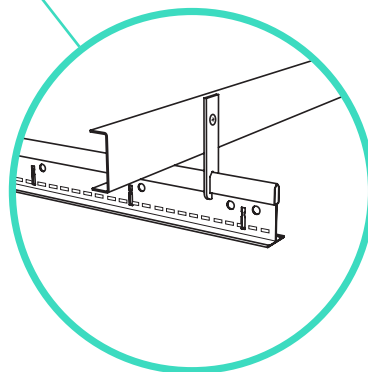

T-bar hanger
A WDN 21 H

05 The Grid – Cross tees in the air

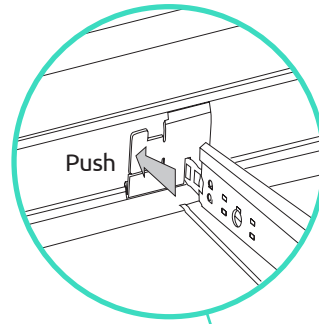
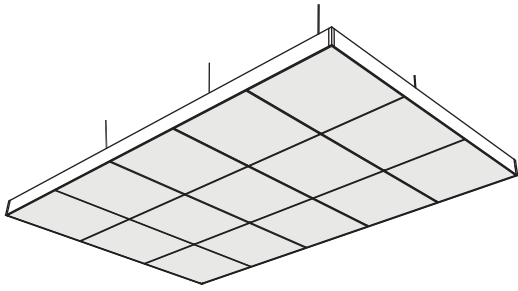

XL² 24 mm Cross Tee
connector clip A 347 G

XL² 15 mm Cross Tee
connector clip A 346 G

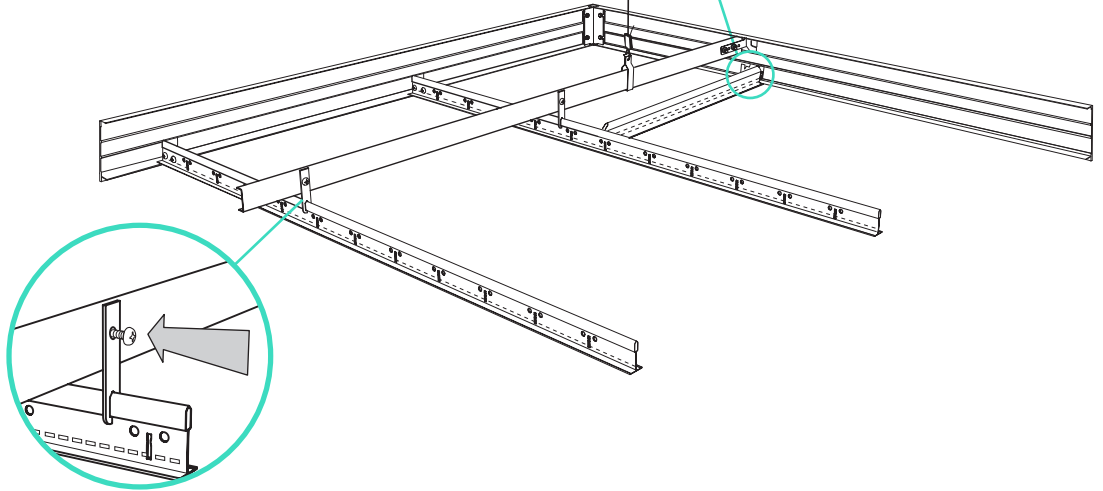

06 The Tiles

The 1.8 x 3.0m module is used as an example only

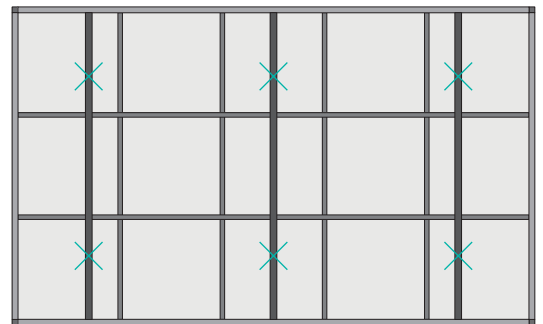

15 Tiles

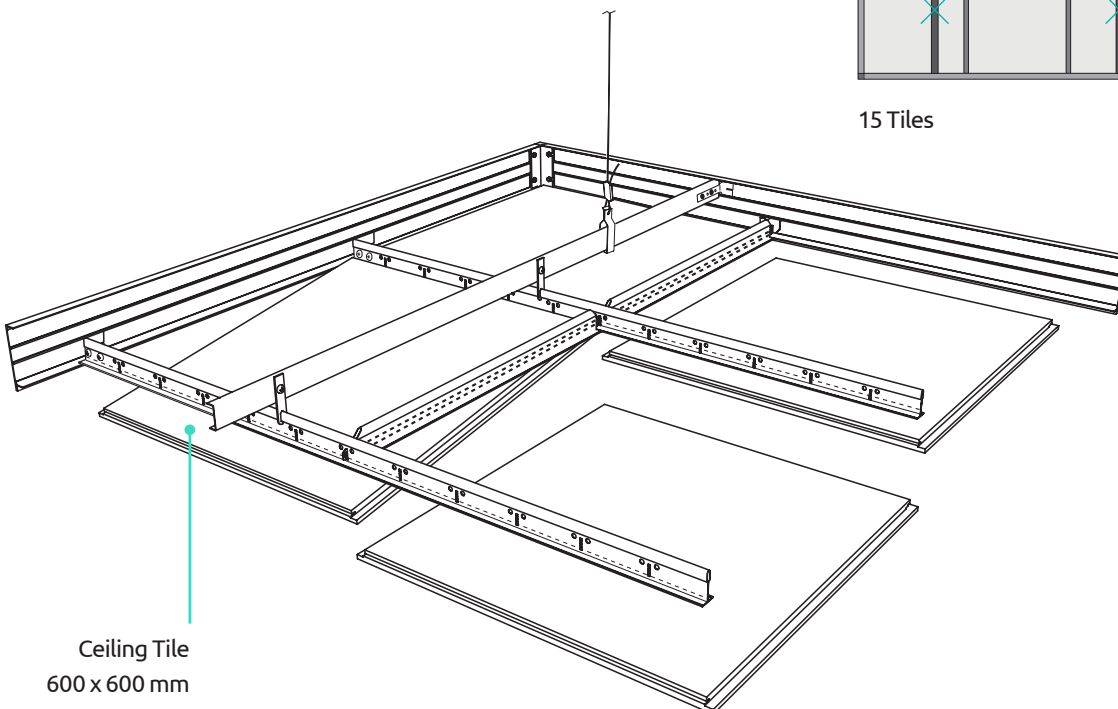

Ceiling Tile
600 x 600 mm

07 Physical Data

Material

- Extruded aluminium profiles
- Axiom C is made from extruded aluminium, offers better registration, handling capability and finished appearance compared with standard cold-rolled steel

Surface finish

- Polyester powder coated
- Global white

Warranty

- For more information, please see our website

Module	Grid system 15 mm XL ² Item No.	Grid system 24 mm XL ² Item No.
1200 x 1200mm	AX 22 G15	AX 22 G24
1800 x 1200mm	AX 32 G15	AX 32 G24
1800 x 1800mm	AX 33 G15	AX 33 G24
2400 x 1200mm	AX 42 G15	AX 42 G24
2400 x 1800mm	AX 43 G15	AX 43 G24
2400 x 2400mm	AX 44 G15	AX 44 G24
3000 x 1200mm	AX 52 G15	AX 52 G24
3000 x 1800mm	AX 53 G15	AX 53 G24
3000 x 2400mm	AX 54 G15	AX 54 G24
3000 x 3000mm	AX 55 G15	AX 55 G24

Ceiling tiles are NOT included in the kit.

- Max. tile load: 10 kg/m²

For further information on customised size models please contact Zentia Technical Sales.

Advisory note:

All statements and technical information contained in this brochure, or any publication of the companies named in this brochure, relating to Zentia are based on results obtained under laboratory test conditions.

It is the responsibility of the user to verify with the seller of the products in writing that such statements and information are appropriate to the specific use intended.

Sales of the products and liability of the selling companies are in accordance with the terms and conditions of sale of the selling company.

All product specifications are subject to modifications without prior notice.

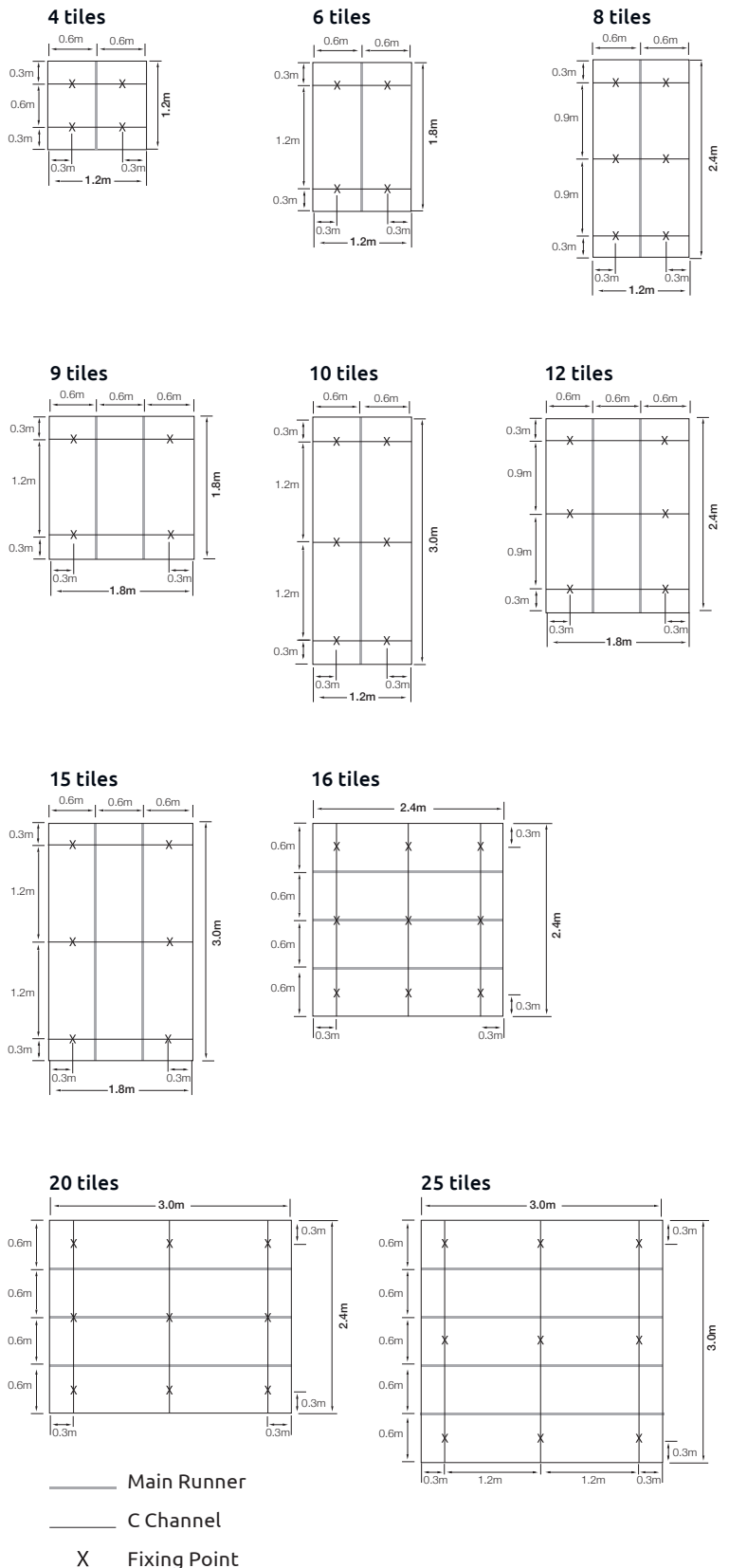

Axiom C Canopy SL2 Planks

Installation Guide



01 Preparation

Axiom C Canopy SL2 Planks Components

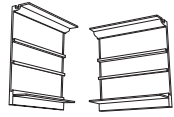

Item No.	Description
55 14 11 G	Axiom C Canopy Profile
C 3000 H	C Channel 19 x 38mm
CZ 41 494 J	Z-bar 30.5mm
CZ 41 794 J	Z-bar 30.5mm
A 345 G	Axiom Vector MicroLook Tegular Profile corner post
A 348 G	Channel Bracket for Canopy (Aircraft cable included in the kit)
CA 97 H	Clamp for C channel
A 339 J	Axiom Universal T-bar connector clip for cut tees with screws

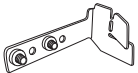
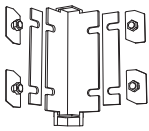
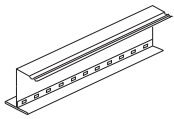
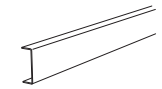

Axiom C Canopy is a modular suspension system supplied kit with ready-to-assemble components (partly listed above).

Initial Recommendations

- ✔ Axiom C Canopies should always be installed in accordance with all applicable building codes and regulations.
- ✔ Axiom C Canopies, as any other architectural feature located in the ceiling plane, may obstruct or skew the existing or planned fire sprinkler distribution pattern or even delay the activation of the fire detection system. Designers and installers are advised to consult a fire protection engineer for guidance on the proper installation techniques where fire detection or suppression systems are present.
- ✔ Any additional load (such as light spots) **MUST NOT** be suspended from the canopy but independently from the soffit.
- ✔ Axiom C Canopies should be always installed on a horizontal plane.
- ✔ Axiom C Canopies are only suitable for indoor applications.
- ✔ Axiom C Canopies can reach a significant weight. In order to minimise the risk of injuries, the canopies should be installed by a minimum of 2 people.
- ✔ Suspension elements such as threaded rods, anchors or any other element not included in the kit must be chosen to ensure a safe installation and follow local regulations.
- ✔ It is recommended to assemble the canopy under the final ceiling location to avoid later movement.

Gloves supplied in the kit are used to prevent marking the components during installation. They are **NOT** meant to be used as safety gloves.

01 Preparation

Suspension Points

Suspension points should be determined before installing the canopy.

See the recommended suspension point matrix on the last page of this guide.

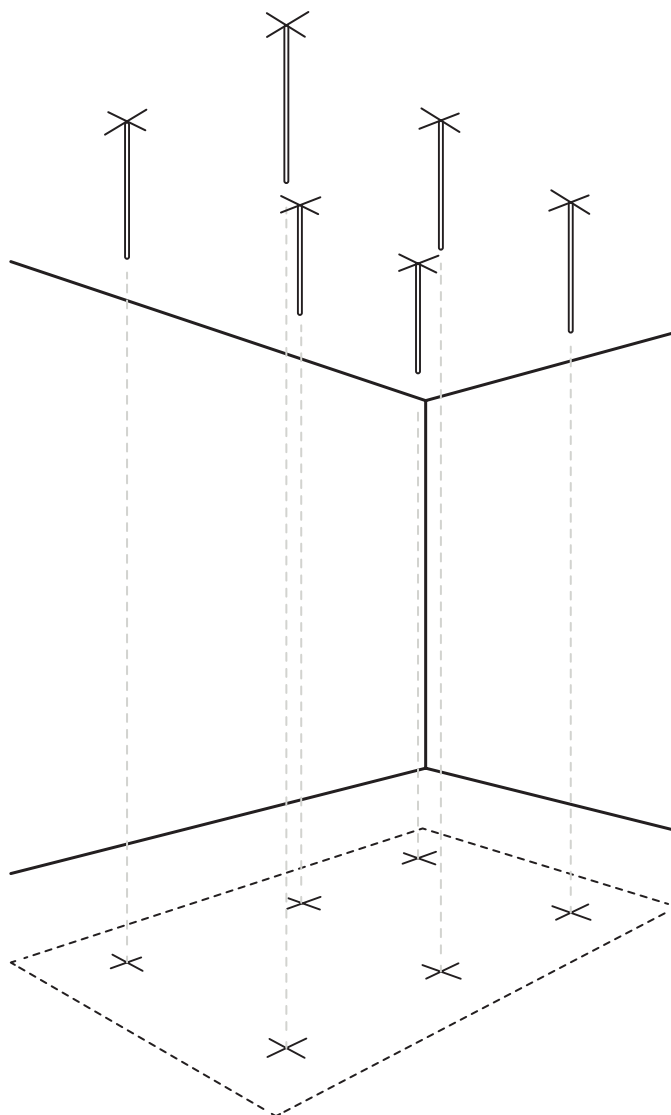

1.8 x 3m module

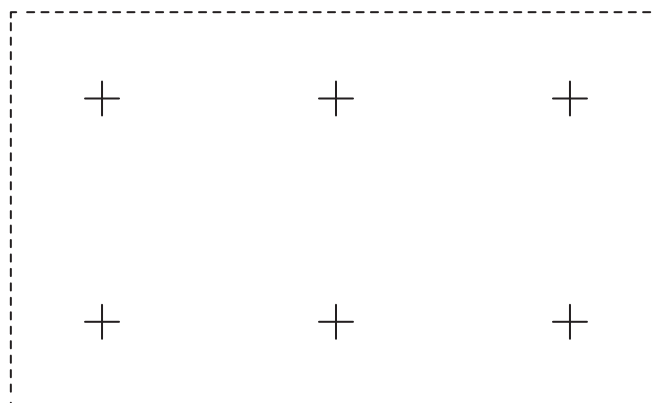

02 The Chassis on the floor

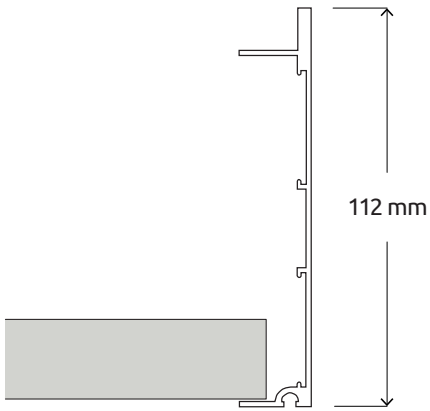

Axiom Profile Vector / Tegular 55 14 11 G

The 1.8 x 3.0m module is used as an example only

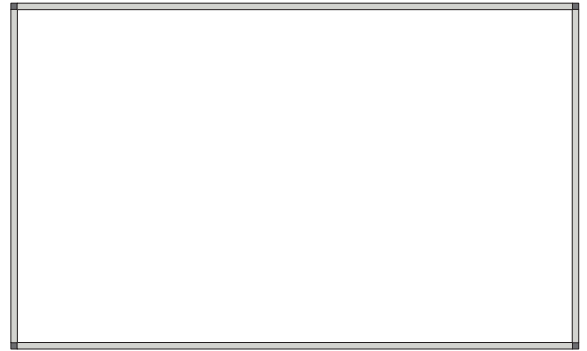

4 Axiom profiles / 4 corner posts

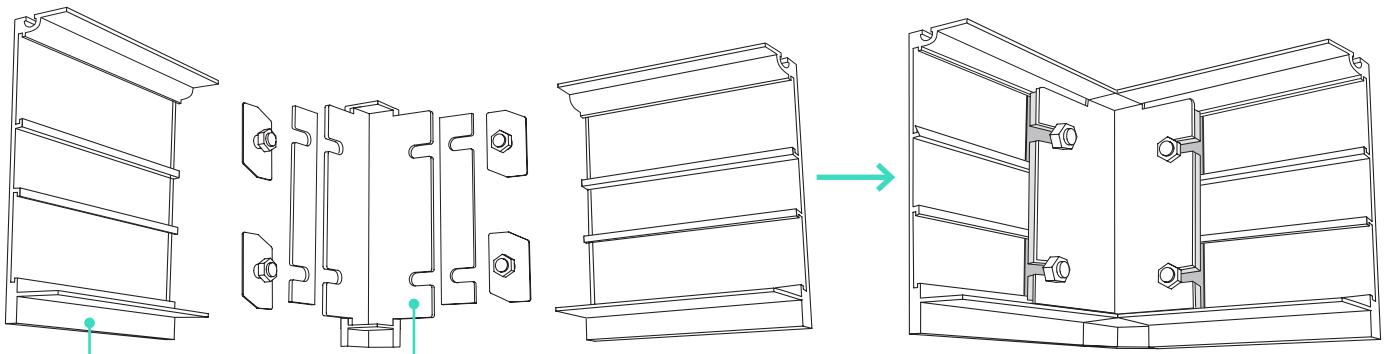
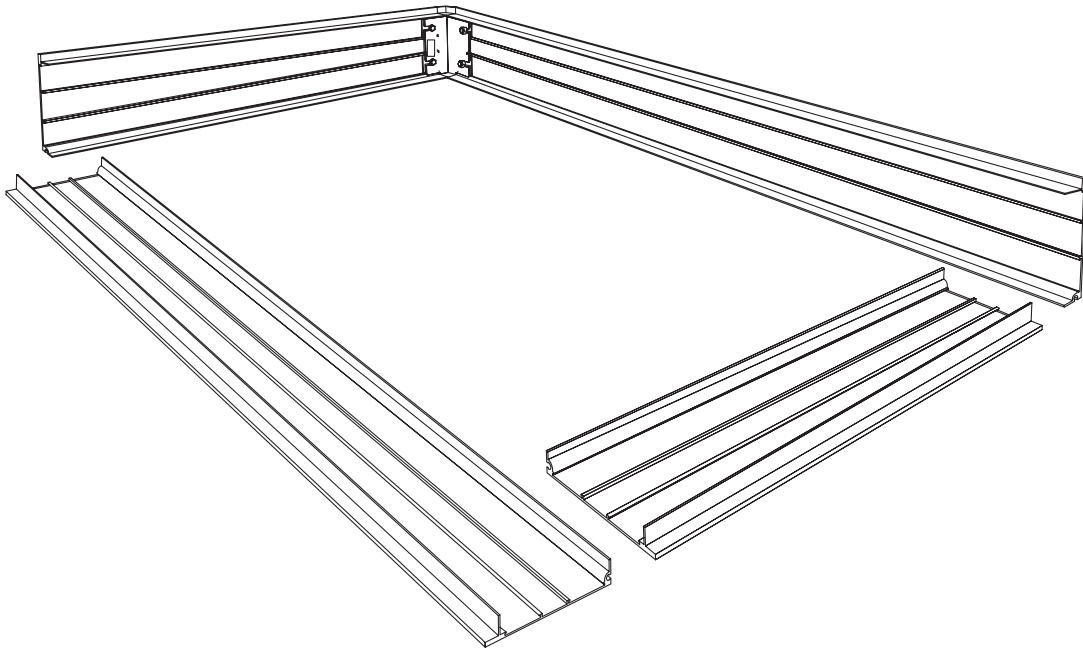

Axiom Profile

Corner Post A 345 G

03 The Primary Grid on the floor

The 1.8 x 3.0m module is used as an example only

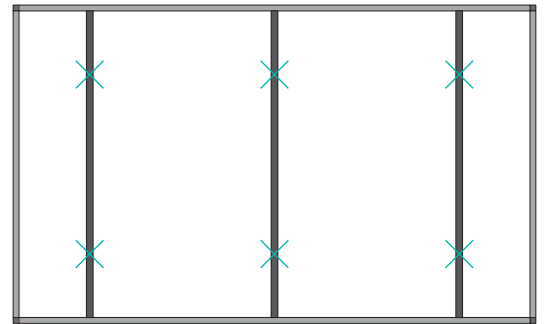

3 C Channels / 6 Connector clips

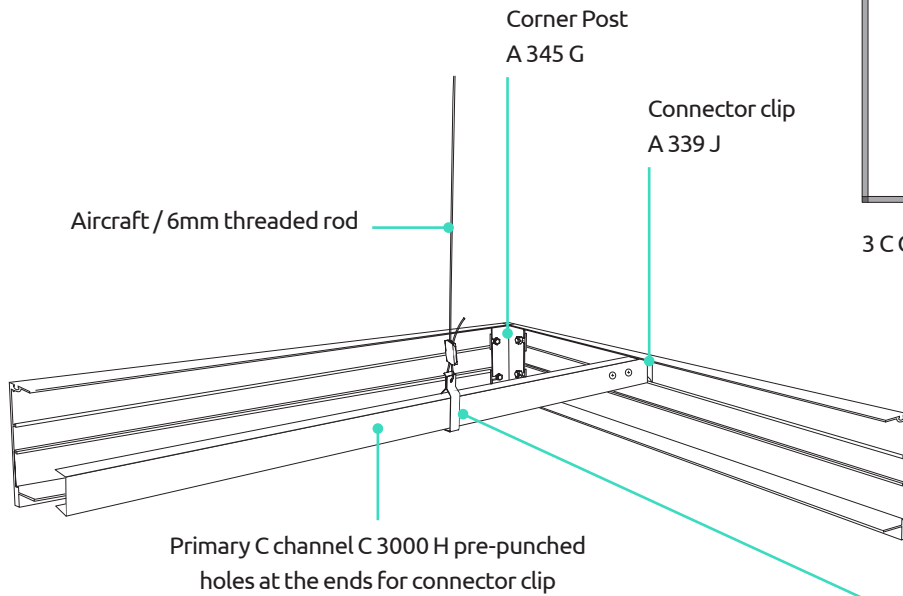

Suspension options

1 Axiom Universal
T-bar connector clip
A 339 J

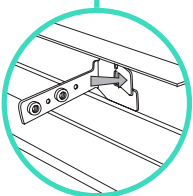
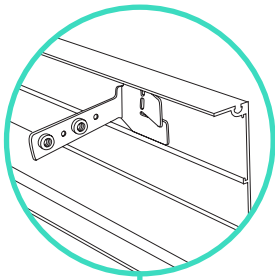

2

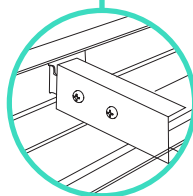
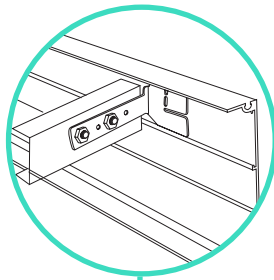

3

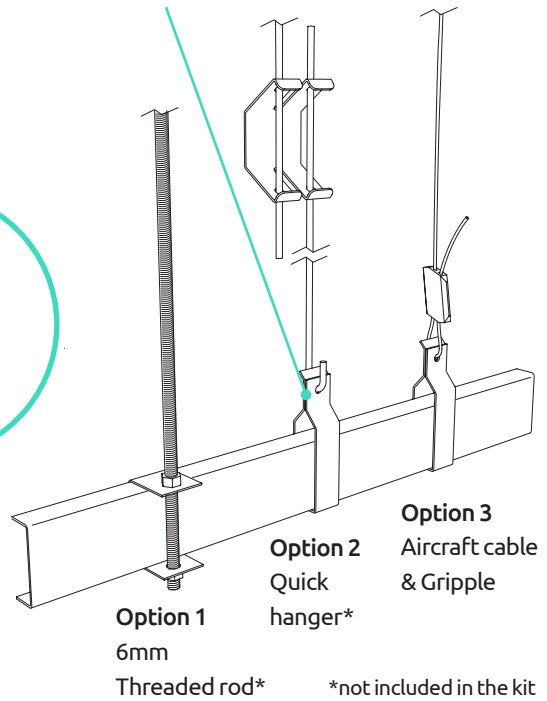
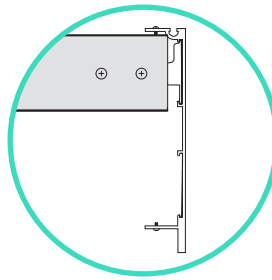

04 The Planks & Z-Profiles

in the air

The 1.8 x 3.0m module is used as an example only

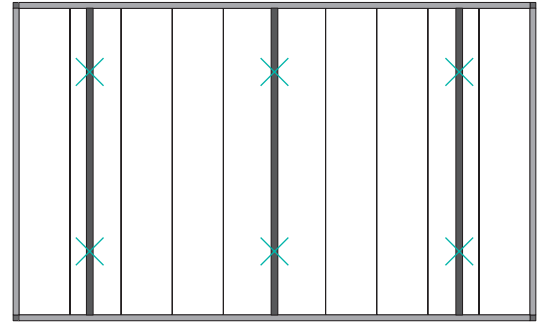
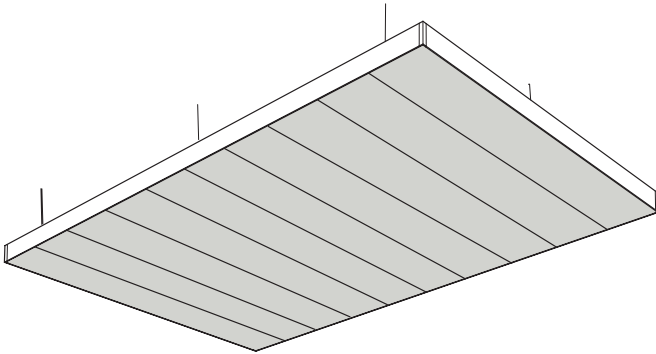

- 9x Deep Z – 30.5 mm
- 6x Clamps for C Channel
- Set of screws
- 6x Channel brackets

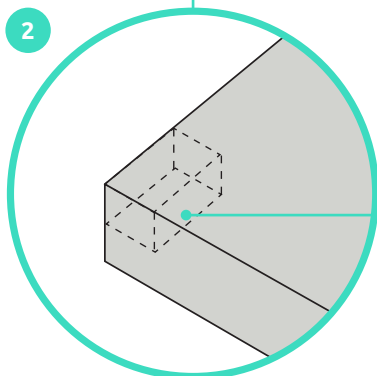
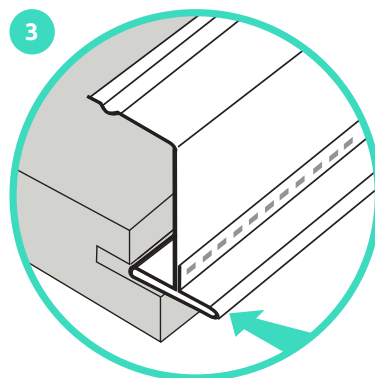
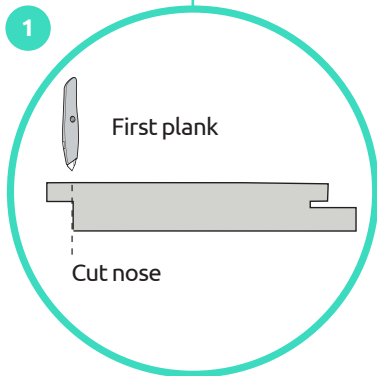
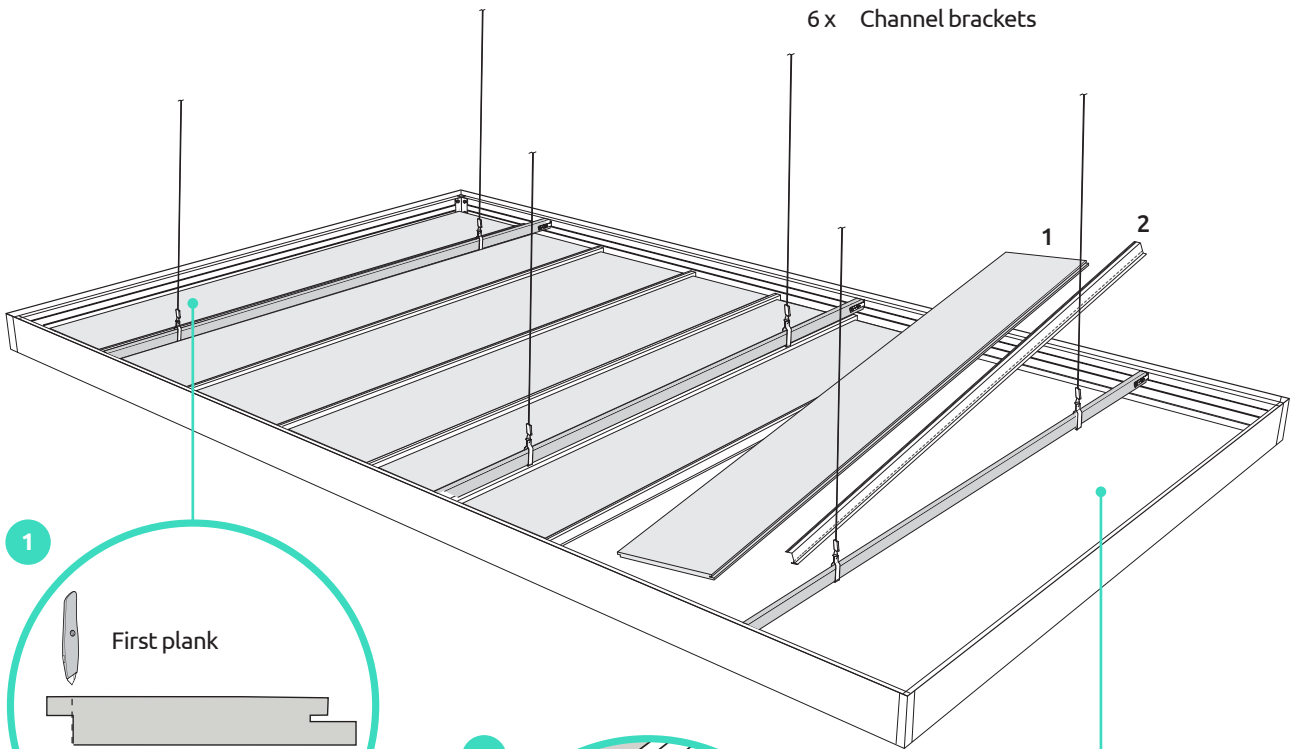

Cut off for
Corner Post screws

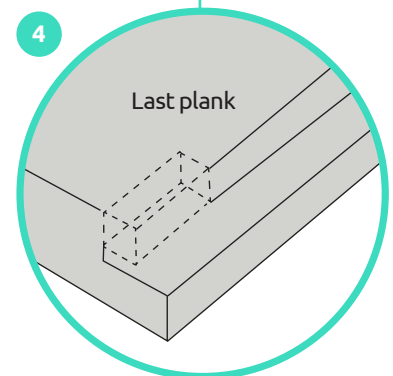

Last plank

05 Physical Data

Material

- Extruded aluminium profiles
- Axiom C is made from extruded aluminium, offers better registration, handling capability and finished appearance compared with standard cold-rolled steel

Surface finish

- Polyester powder coated
- Global white

Warranty

- For more information, please see our website

6 pre-packed, ready-to-assemble Axiom C Canopy SL2 planks kit will be available.

Module	Item No.
1800 x 1500mm	AX 22 36G SL2
2400 x 1500mm	AX 22 46G SL2
3000 x 1500mm	AX 22 56G SL2
1800 x 1800mm	AX 22 33G SL2
2400 x 1800mm	AX 22 43G SL2
3000 x 1800mm	AX 22 53G SL2

Ceiling tiles SL2 are NOT included in the kit.

- Max. tile load: 10 kg/m²

For further information on customised size models please contact Zentia Technical Sales.

Advisory note:

All statements and technical information contained in this brochure, or any publication of the companies named in this brochure, relating to Zentia are based on results obtained under laboratory test conditions.

It is the responsibility of the user to verify with the seller of the products in writing that such statements and information are appropriate to the specific use intended.

Sales of the products and liability of the selling companies are in accordance with the terms and conditions of sale of the selling company.

All product specifications are subject to modifications without prior notice.

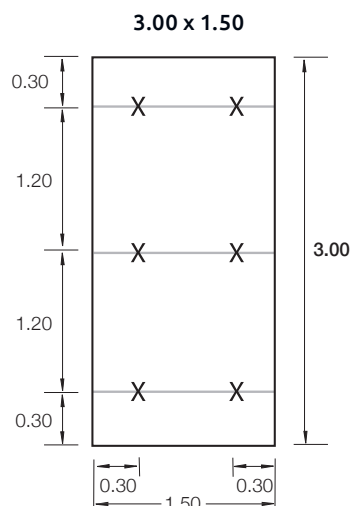
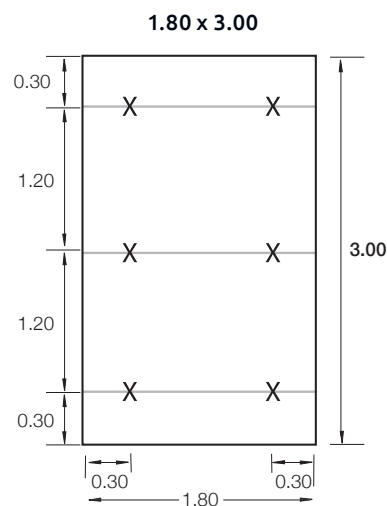
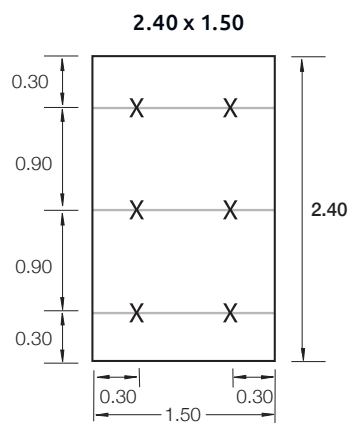
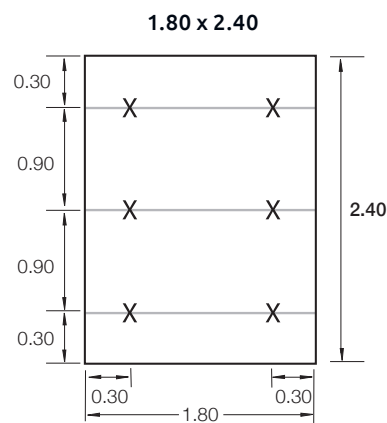
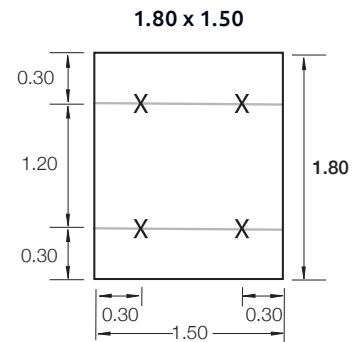
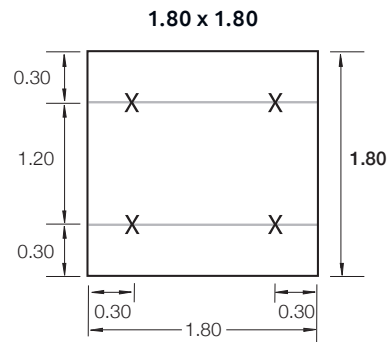

Axiom KE Canopy

Installation Guide

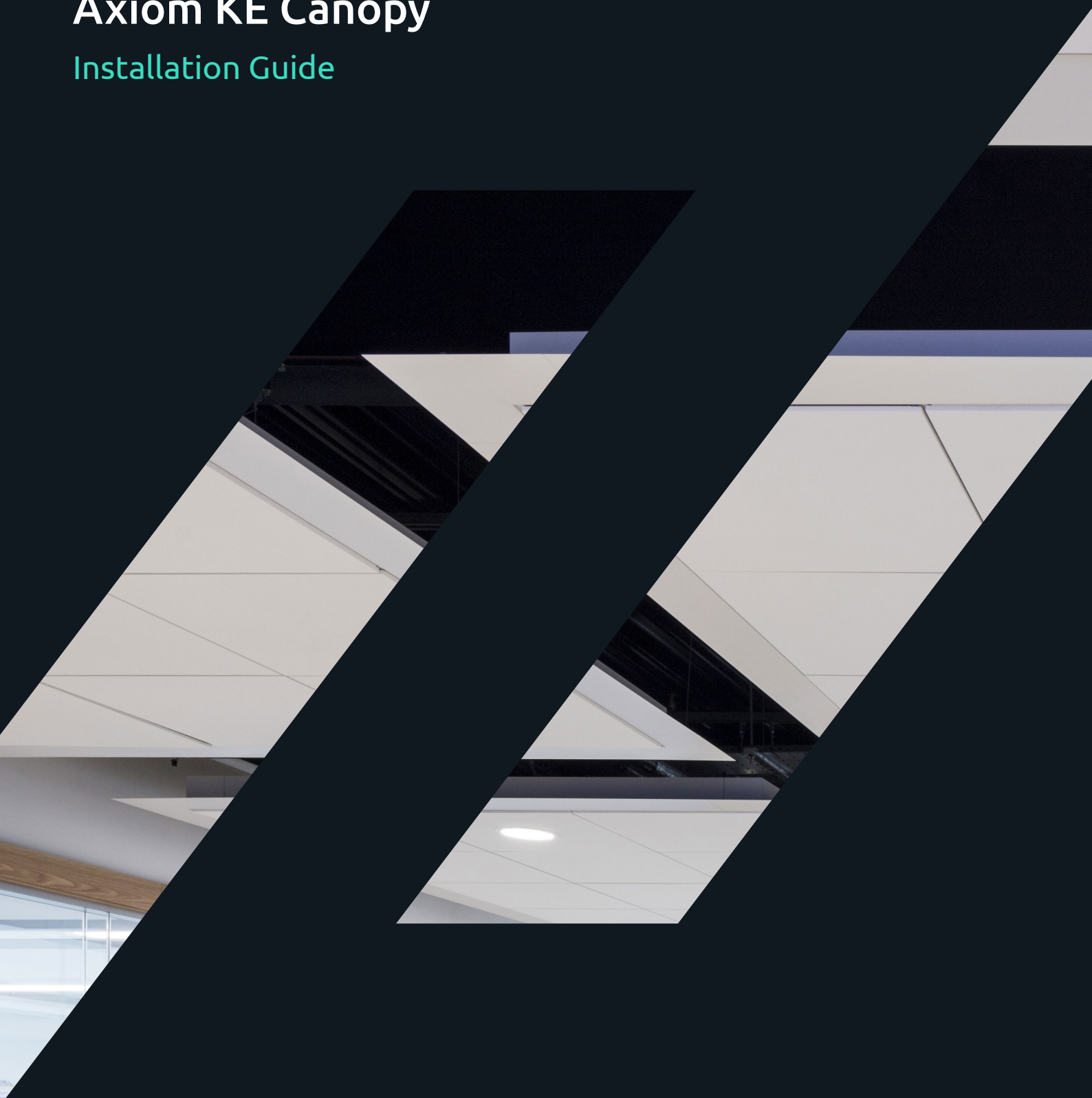

01 Preparation

Axiom KE Canopy Components

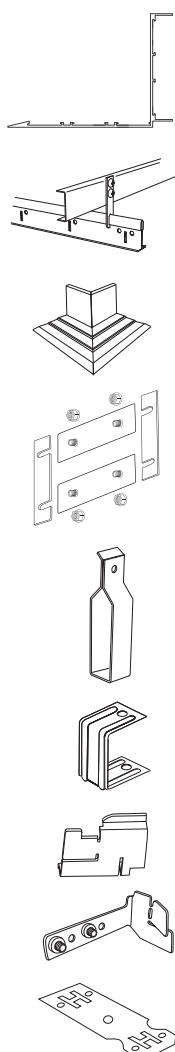

Item No.	Description
CS 57420 G	Axiom KE Canopy profile
C 3000 H	C Channel 19 x 38mm
A WDN 21 H	T-bar hanger
CS 57 G	Mitre corner piece
A 361 G	Mitre corner splice connector
A 348 G	Channel Bracket for Canopy (Aircraft cable included in the kit)
CA 97 H	Clamp for C channel
A 347 G	24mm XL ² connector clip
A 346 G	15mm XL ² connector clip
A 339 J	Axiom Universal t-bar connector clip for cut tees with screws
A 338 H	Axiom universal splice plate

Axiom KE Canopy is a modular suspension system supplied kit with ready-to-assemble components (partly listed above).

Initial Recommendations

- ✔ Axiom KE Canopies should always be installed in accordance with all applicable building codes and regulations.
- ✔ Axiom KE Canopies, as any other architectural feature located in the ceiling plane, may obstruct or skew the existing or planned fire sprinkler distribution pattern or even delay the activation of the fire detection system. Designers and installers are advised to consult a fire protection engineer for guidance on the proper installation techniques where fire detection or suppression systems are present.
- ✔ Any additional load (such as light spots) MUST NOT be suspended from the canopy but independently from the soffit.
- ✔ Axiom KE Canopies should be always installed on a horizontal plane.
- ✔ Axiom KE Canopies are only suitable for indoor applications.
- ✔ Axiom KE Canopies can reach a significant weight. In order to minimise the risk of injuries, the canopies should be installed by a minimum of 2 people.
- ✔ Suspension elements such as threaded rods, anchors or any other element not included in the kit must be chosen to ensure a safe installation and follow local regulations.
- ✔ It is recommended to assemble the canopy under the final ceiling location to avoid later movement.

Gloves supplied in the kit are used to prevent marking the components during installation. They are **NOT** meant to be used as safety gloves.

01 Preparation

Suspension Points

Suspension points should be determined before installing the canopy.

See the recommended suspension point matrix on the last page of this guide.

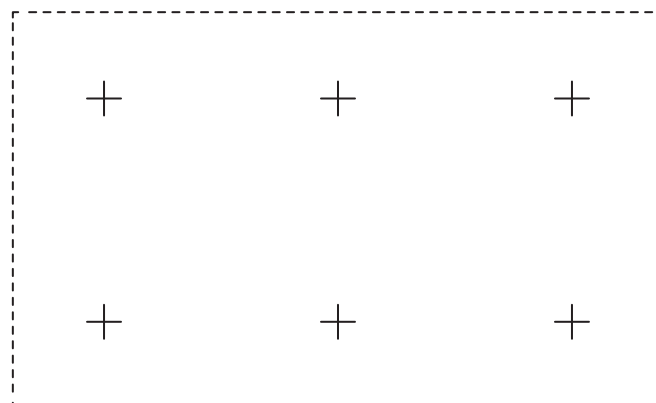
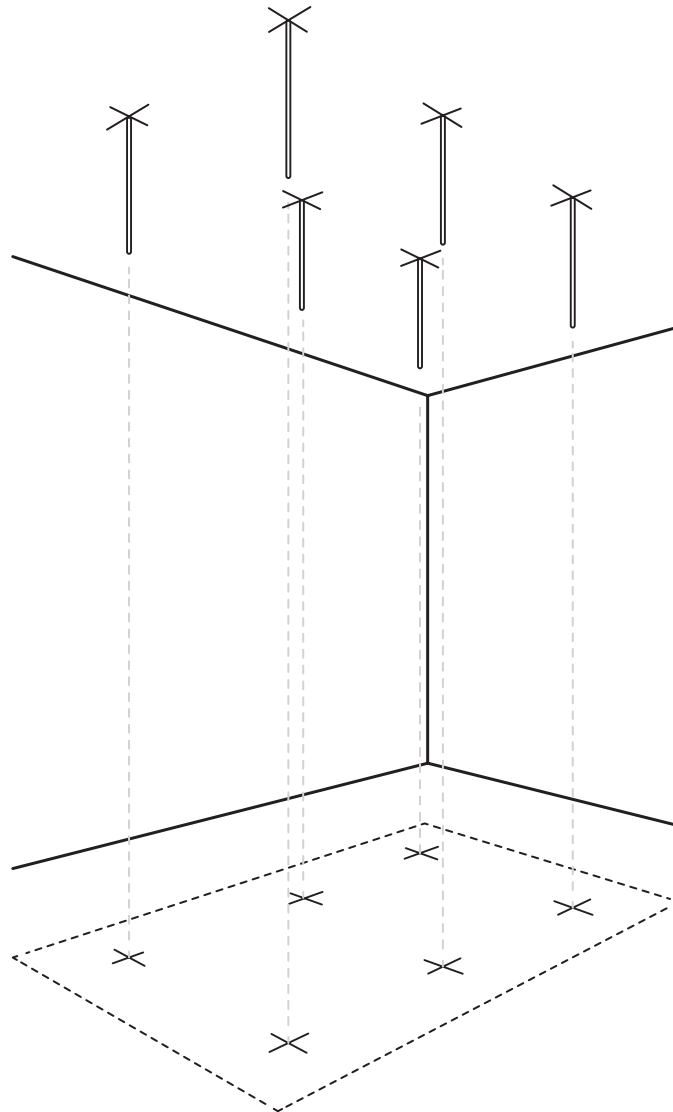

02 The Chassis on the floor

Axiom KE Canopy profile CS 574206 G

The 1.8 x 3.0m module is used as an example only

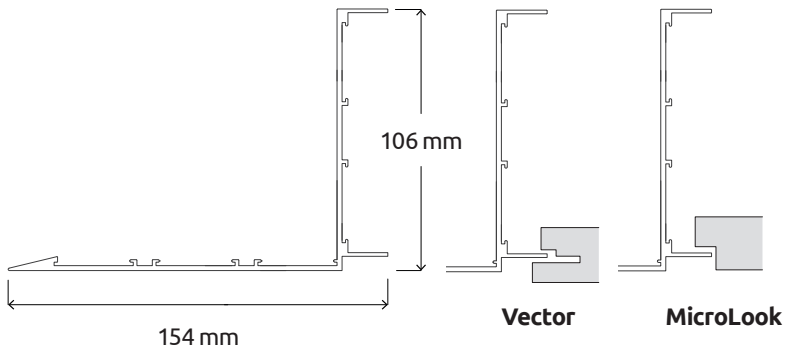

- 4 x Axiom profiles
- 4 x Mitre corner pieces
- 16 x Axiom universal splice plates
- 8 x Mitre corner splice connectors

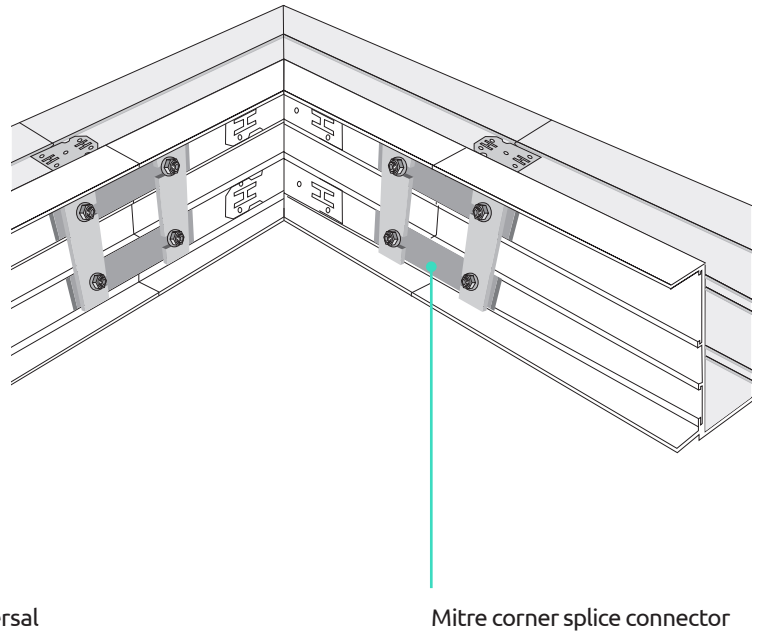
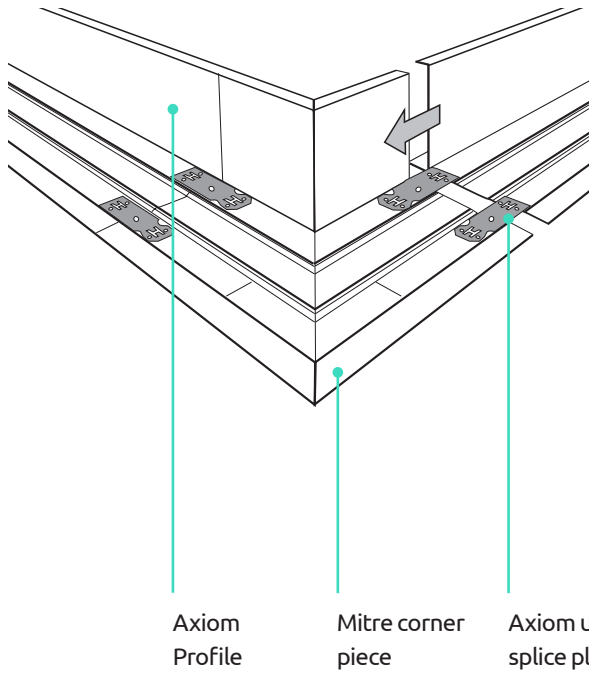

03 The Primary Grid

on the floor

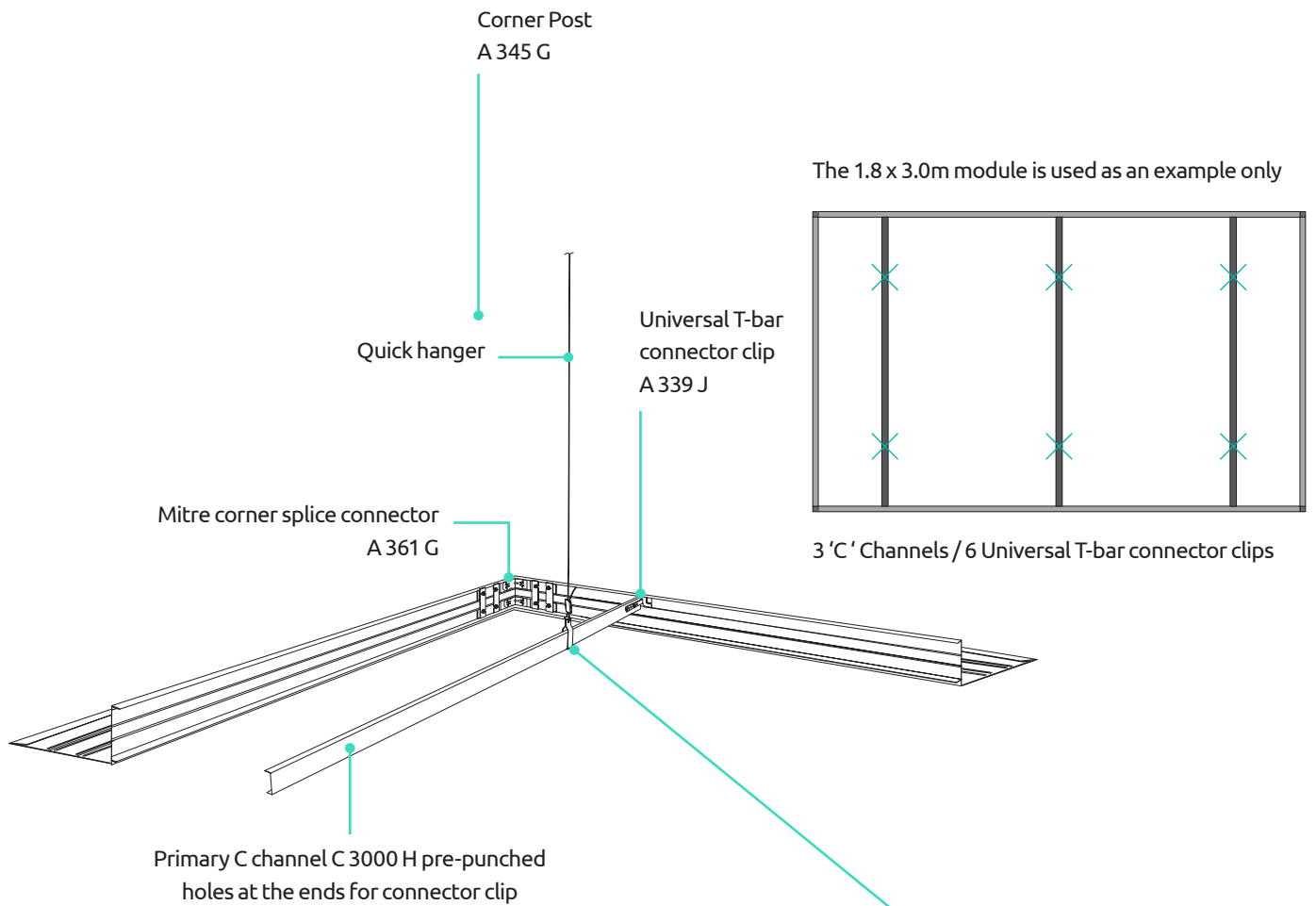

Suspension options

1 Axiom Universal
T-bar connector clip
A 339 J

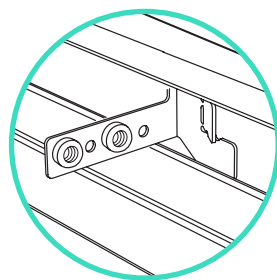

2

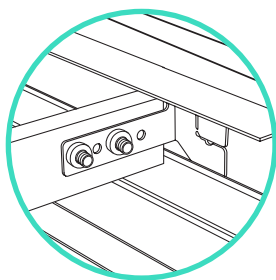

3

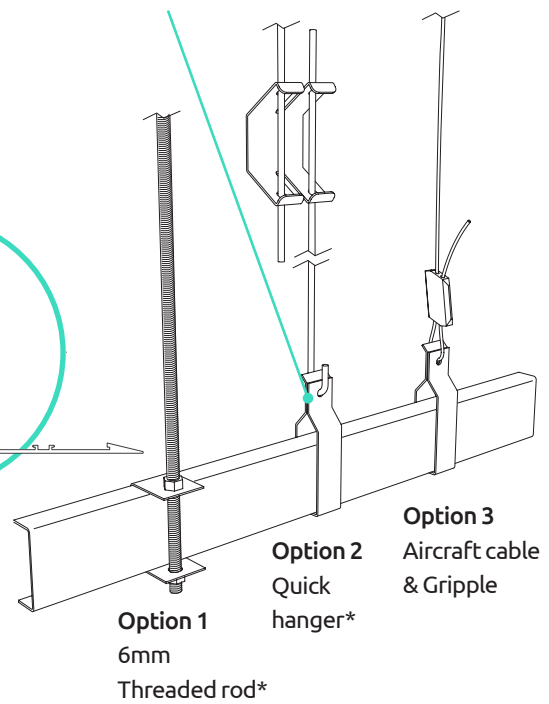
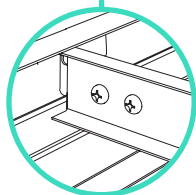
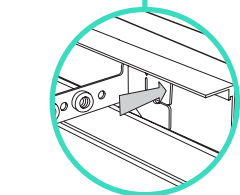
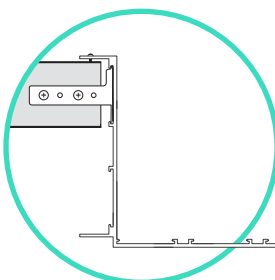

04 The Grid – Main Runner in the air

The 1.8 x 3.0m module is used as an example only

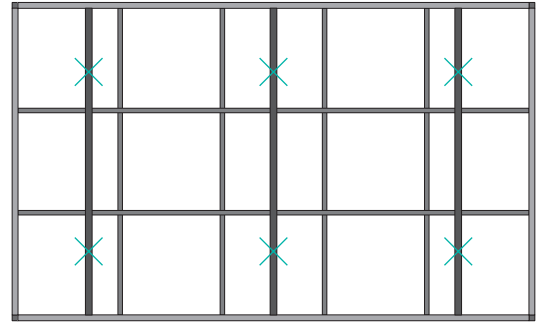

- 2 x Main runners
- 12 x XL² Cross tees
- 10 x Universal T-bar connector clips
- 8 x XL² Cross tee connector clips
- 6 x Clamps for C channel
- Set of screws
- 6 x Channel brackets
- 6 x T-bar hangers

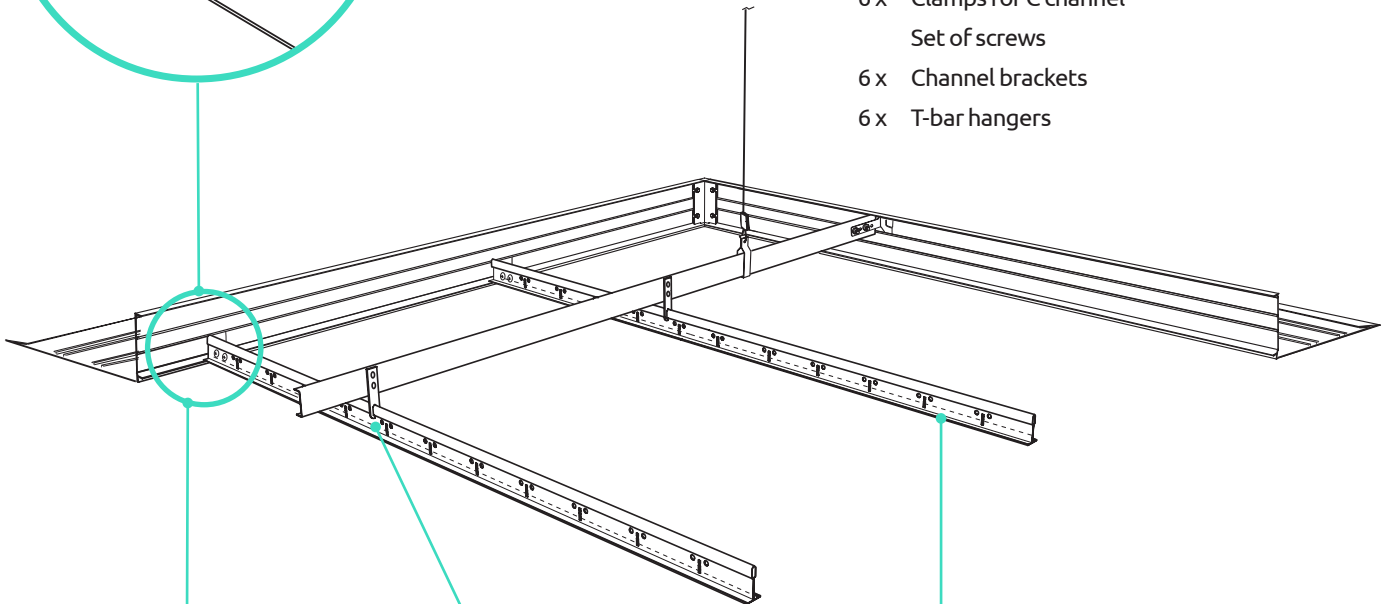
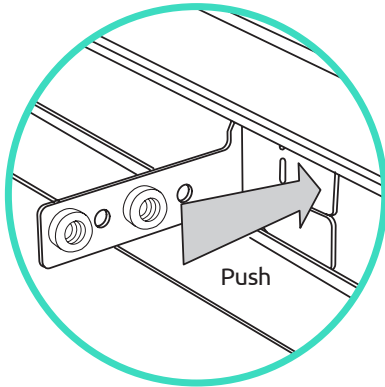

Main runner

Pre cut according to cloud size
Pre-punched holes at the end of alignment
with Universal T-bar connector clip

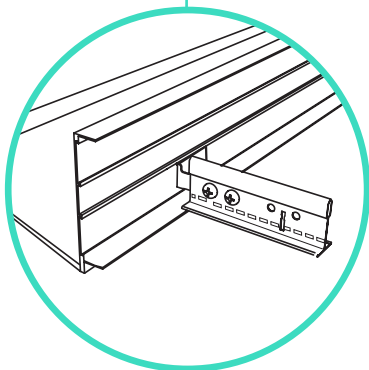

Universal T-bar connector
clip A 339 J

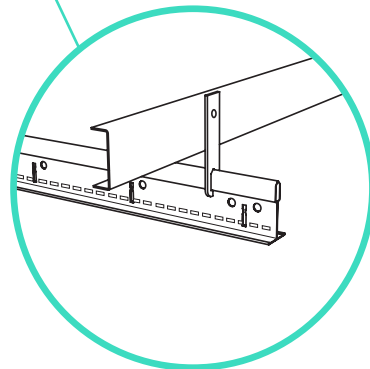

T-bar hanger
A WDN 21 H

05 The Grid – Cross Tees in the air

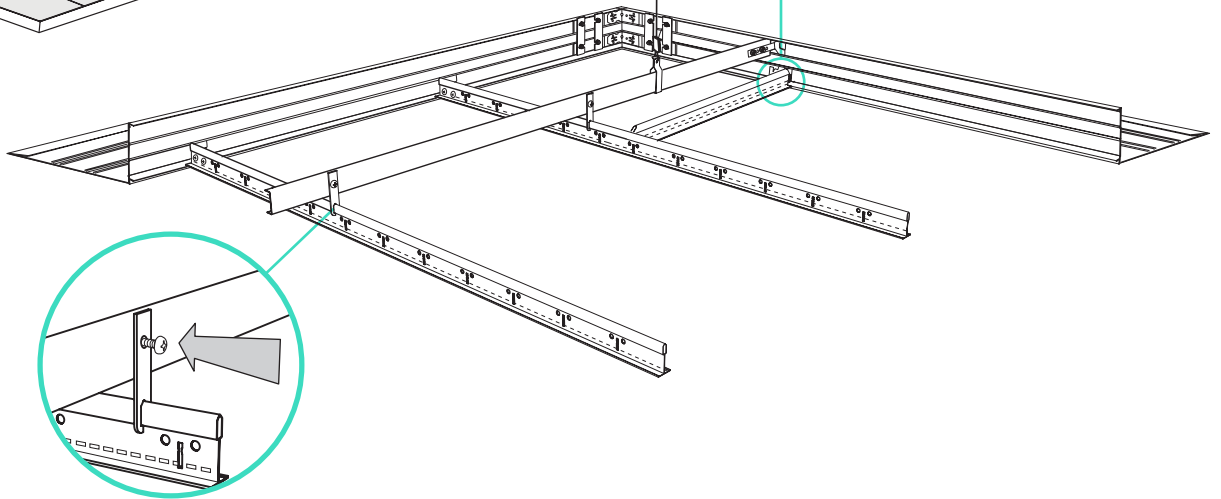
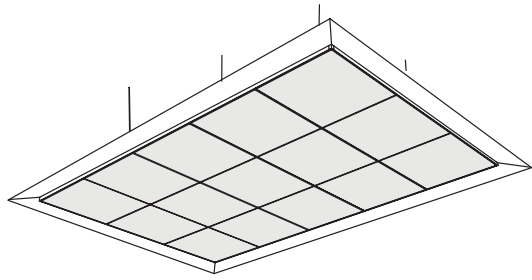

Push

XL² 24 mm Cross Tee
connector clip A 347 G

XL² 15 mm Cross Tee
connector clip A 346 G

06 The Tiles

The 1.8 x 3.0m module is used as an example only

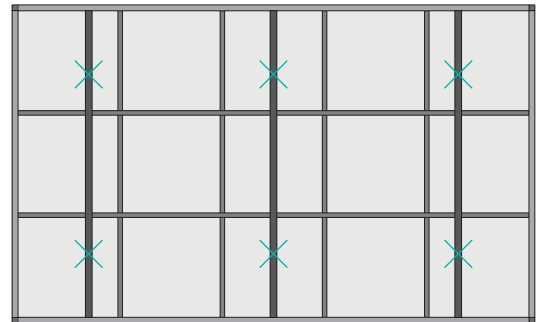

15 Tiles

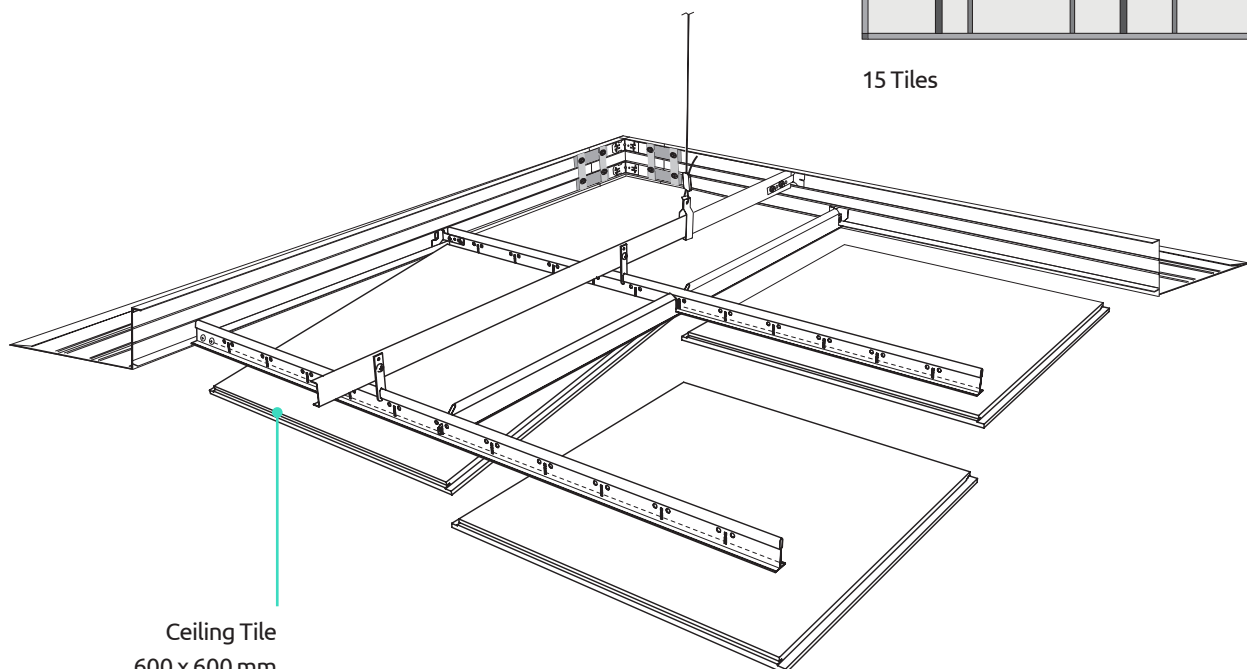

Ceiling Tile
600 x 600 mm

Axiom Circle & Curved Canopies

for Tegular 8mm & MicroLook 8mm reveal edge tiles

Installation Guide



01 Preparation

Axiom Circle & Curved Canopies components*

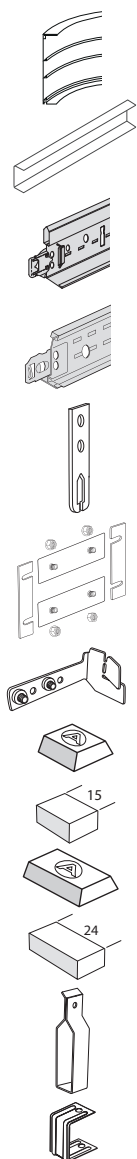

Item No.	Description
62 42 06 G	Axiom Circle and Curved Profile
C 3000 H	Primary C-Channel
30 40 33 A	Prelude Peakform Main Runner T15 or
31 40 32 A	Prelude Peakform Main Runner T24
30 20 33 B	Prelude Cross Tee 600mm T15 or
31 20 21 A	Prelude Cross Tee 600mm T24
AWDN 21 H	T-bar hanger
A 361 G	Splice connector
A 339 H	T-bar connector clip (threaded) + M4 bolts (cross head)
A 156 G	Perimeter fill-in for 15mm grid
A 157	Perimeter fill-in for 15mm grid
A 246 G	Perimeter fill-in for 24mm grid
A 247	Perimeter fill-in for 24mm grid
A 348 G	Channel bracket (Aircraft cable included in the kit)
CA 97 H	Clamp for C-Channel

Axiom Circle and Curved Canopy is a modular suspension system supplied kit with ready-to-assemble components (partly listed above). *For further detailed information regarding any of these items please refer to the parts lists included in the carton. All the profiles on the kits are cut and pre-drilled following the dimensions of the Canopy.

Initial Recommendations

- // Axiom Circle & Curved Canopies should always be installed in accordance with all applicable building codes and regulations.
- // Axiom Circle & Curved Canopies, as any other architectural feature located in the ceiling plane, may obstruct or skew the existing or planned fire sprinkler distribution pattern or even delay the activation of the fire detection system. Designers and installers are advised to consult a fire protection engineer for guidance on the proper installation techniques where fire detection or suppression systems are present.
- // Any additional load (such as light spots) MUST NOT be suspended from the canopy but independently from the soffit.
- // Axiom Circle & Curved Canopies should be always installed on a horizontal plane.
- // Axiom Circle & Curved Canopies are only suitable for indoor applications.
- // Axiom Circle & Curved Canopies can reach a significant weight. In order to minimise the risk of injuries, the canopies should be installed by a minimum of 2 people.
- // Suspension elements such as threaded rods, anchors or any other element not included in the kit must be chosen to ensure a safe installation and follow local regulations.
- // It is recommended to assemble the canopy under the final ceiling location to avoid later movement.

Gloves supplied in the kit are used to prevent marking the components during installation. They are **NOT** meant to be used as safety gloves.

01 Preparation

Suspension Points

Suspension points should be determined before installing the canopy.

See the recommended suspension point matrix on the last page of this guide.

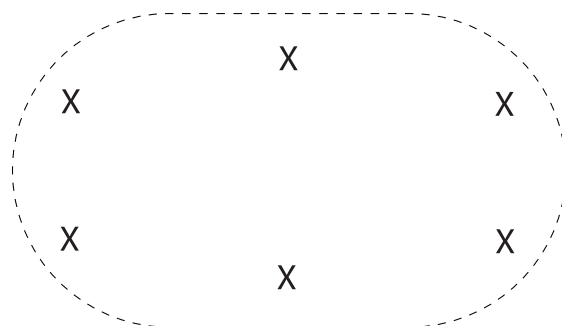
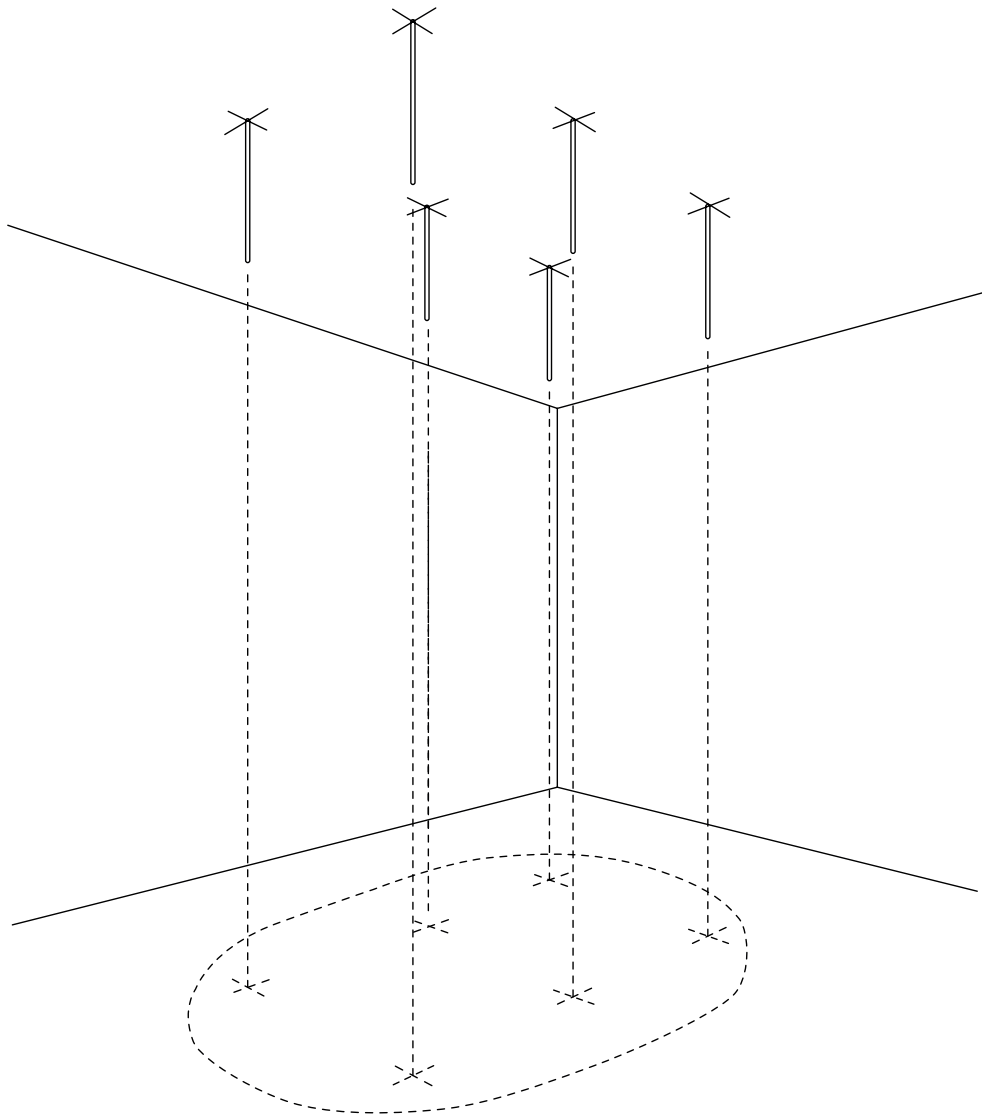

02 The Chassis on the floor

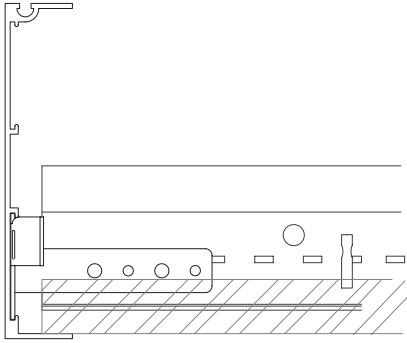

Choose the position of the perimeter section
(Groove facing up or downwards)

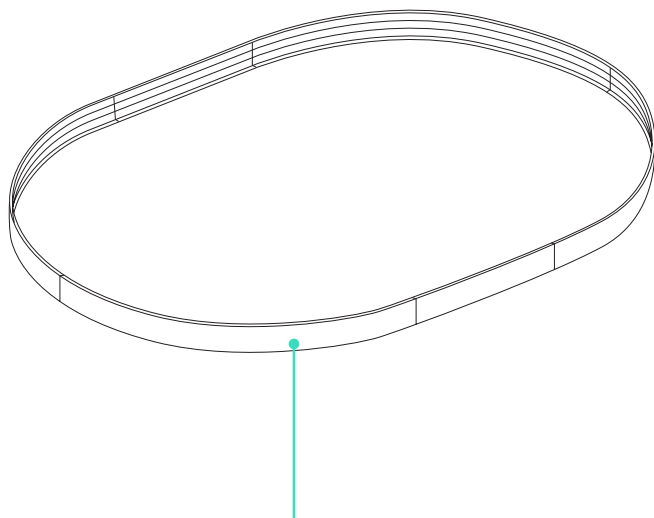
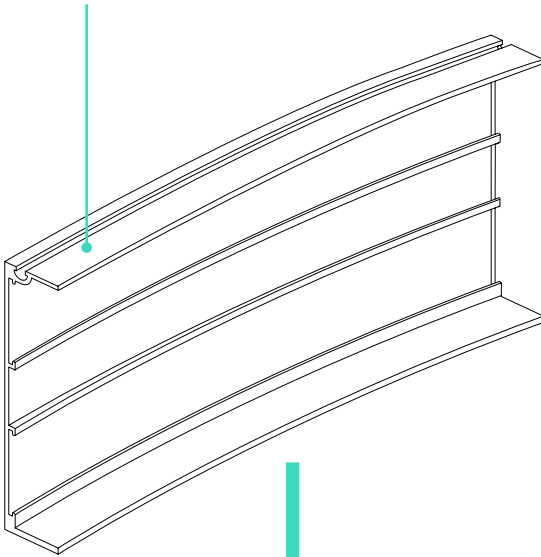

Match the codes (1-1, 2-2,
etc) of the perimeter ends

The 1.8 x 2.4m module is used as an example only

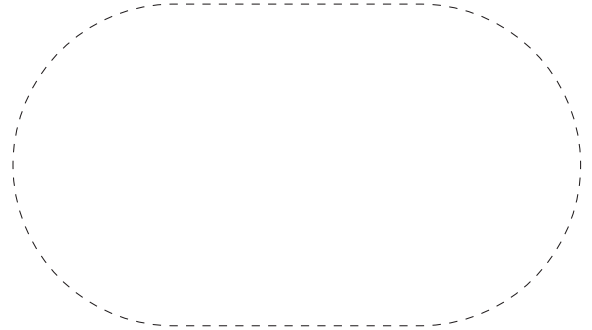

Items needed:

- 2 x Axiom straight profiles
- 4 x Axiom curved profiles
- 6 x Splice connectors

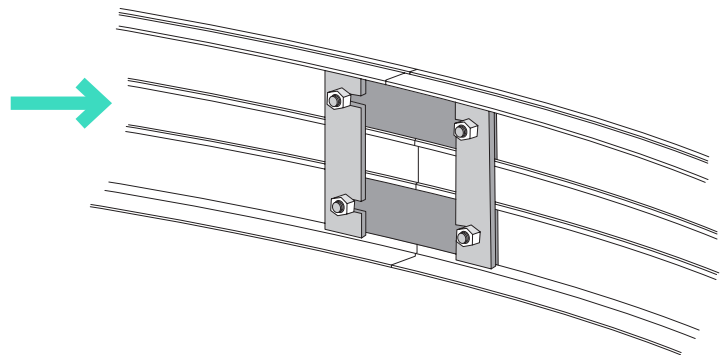

03 The Primary Grid on the floor

The 1.8 x 2.4m module is used as an example only

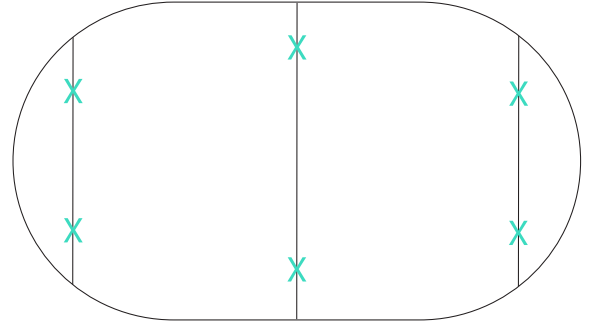

Items needed:

- 3 x C-Channels
- 6 x T-bar connectors
- 6 x Hangers

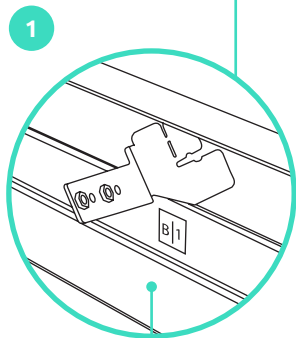
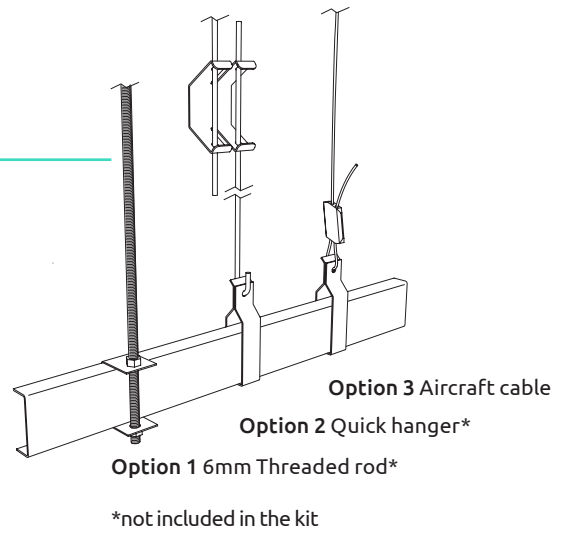
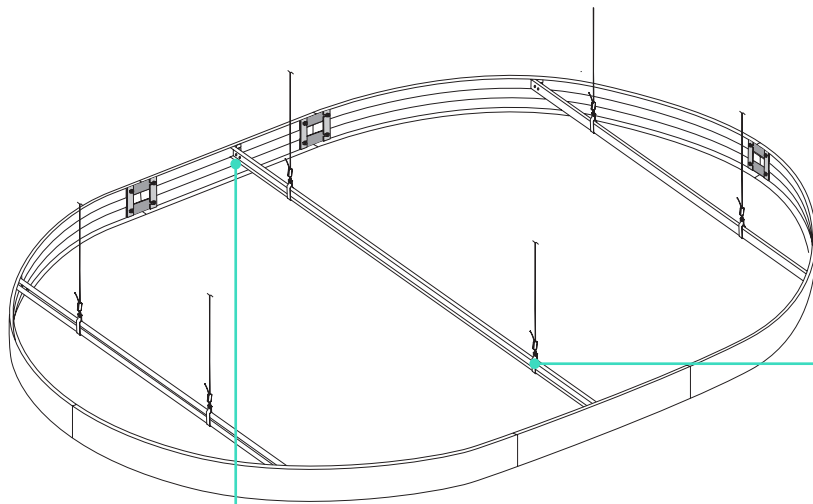

1 Match the positioning stickers attached to the Chassis

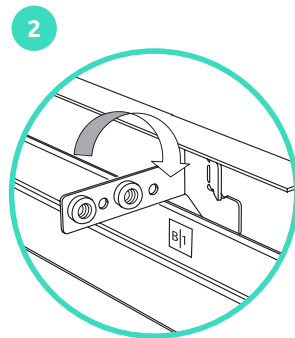

2 **IMPORTANT NOTE:** When there is not enough room for the screwdriver please install the T-bar connectors upside down.

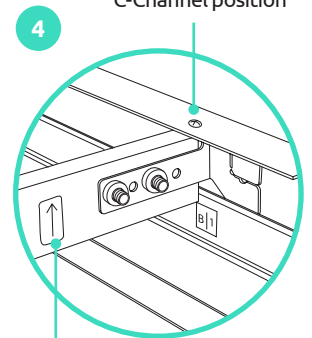
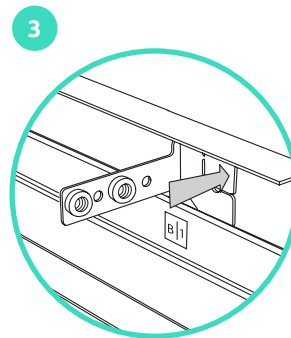

4 Check positioning arrow on the C-Channel

Self tapping screw to secure C-Channel position

04 The Grid – Main Runner in the air

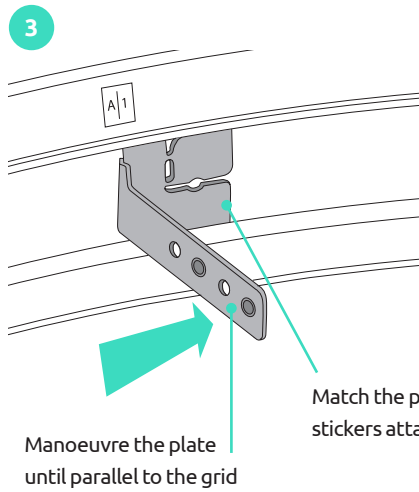
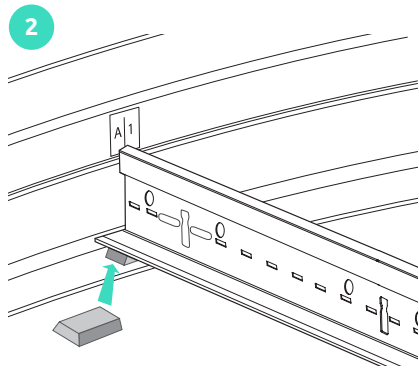
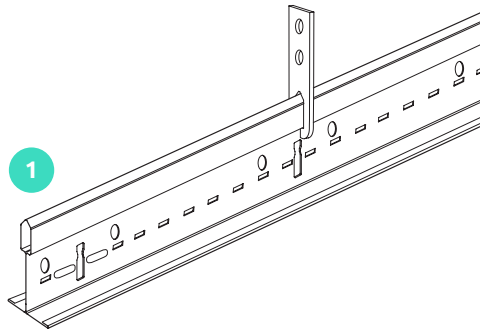

Match the positioning stickers attached to the Chassis

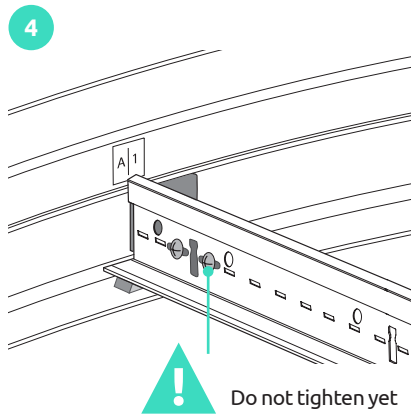

The 1.8 x 2.4m module is used as an example only

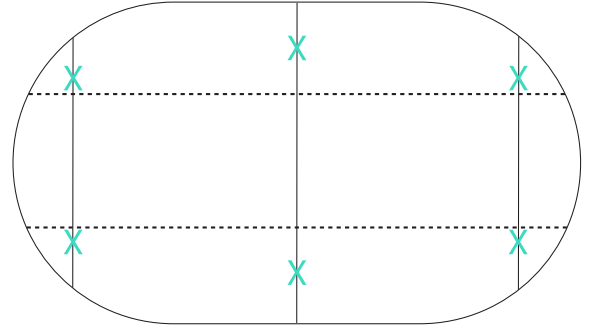

Items needed:

- 2 x Main Runners
- 4 x T-bar connectors
- 4 x Perimeter fill in

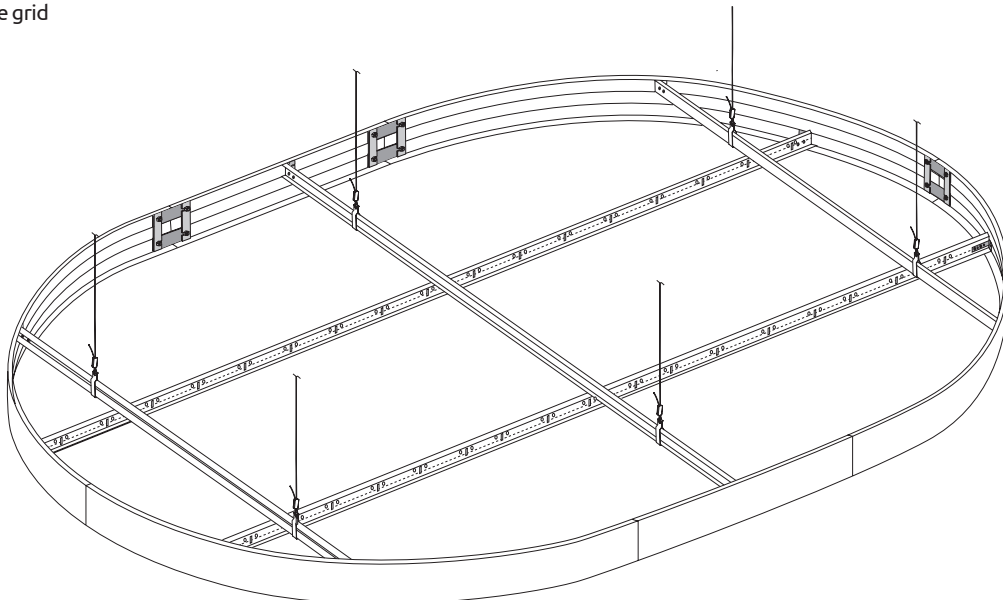

05 The Grid – Cross Tees

in the air

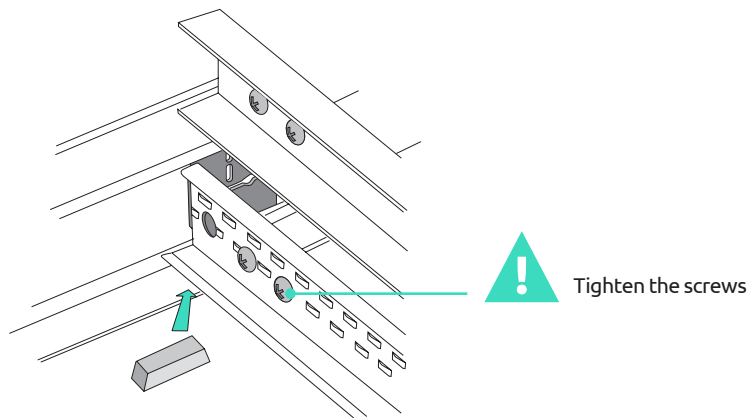
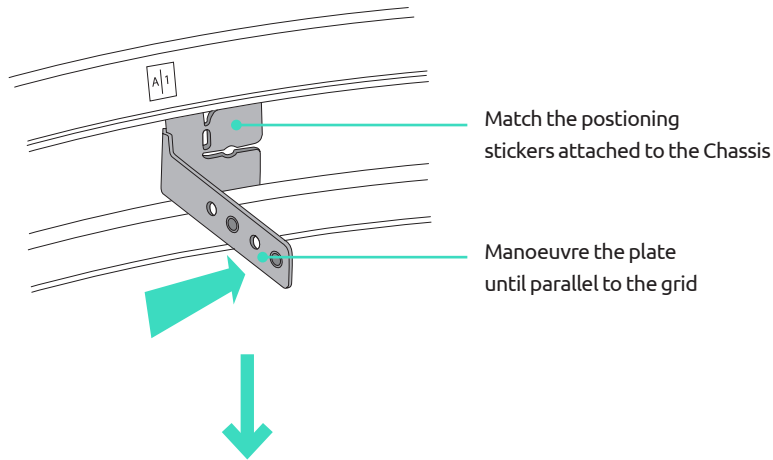

The 1.8 x 2.4m module is used as an example only

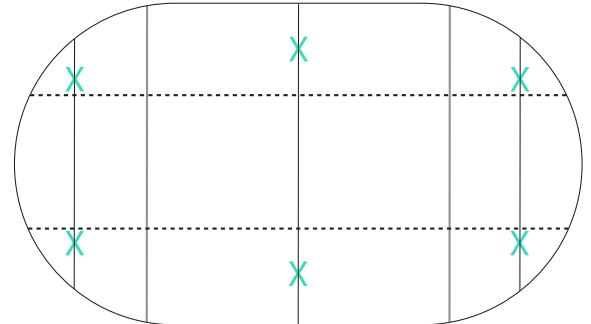

Items needed:

- 3 x Standard Cross Tees
- 6 x Special Cross Tees
- 6 x T-bar connectors
- 6 x Perimeter fill in

- 1 Special Cross Tees
- 2 Standard Cross Tees

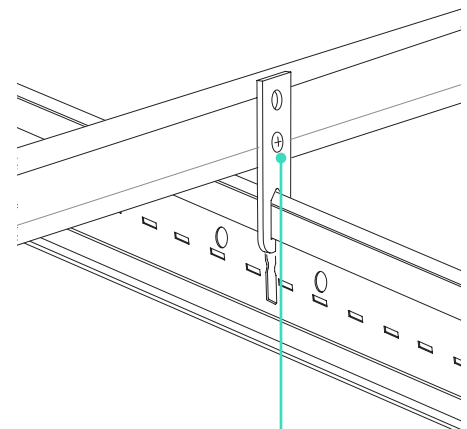
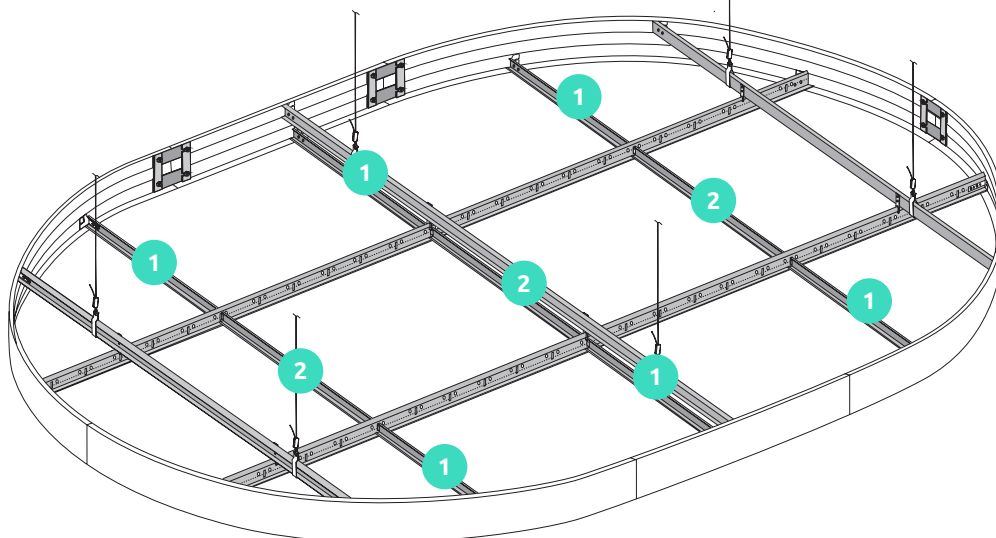

Use self-tapping screws at the marked height line, once the Main Runner and Cross Tees have been centred.

Use a measuring tape to check the centering of the Main Runners and Cross Tees and readjust if needed.

06 The Tiles

For Tegular 8mm & MicroLook 8mm edge reveal tiles

All perimeter tiles are cut on site (Board edge; see drawing page 3) and resting with the face on the Axiom Profile.

1. Cut down the perimeter tiles using the templates provided (see layout below) and install them accordingly.
2. Install the full size / centre tiles/s.

The 1.8 x 2.4m module is used as an example only

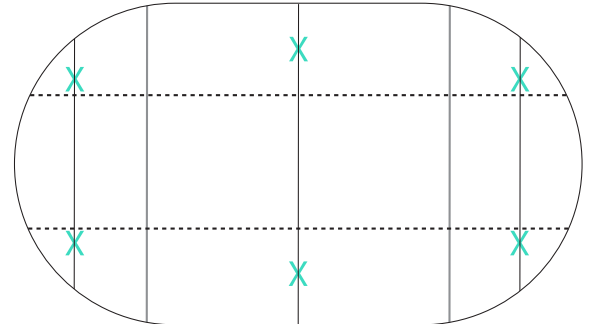

Tile Layout

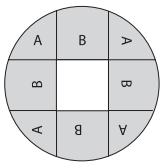

1.8m Canopy
CS ACI 33 G15
CS ACI 33 G24

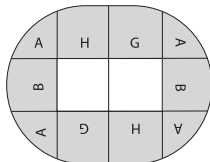

1.8m x 2.4m Canopy
CS ACU 43 G15
CS ACU 43 G24

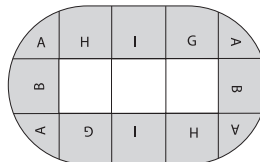

1.8m x 3m Canopy
CS ACU 53 G15
CS ACU 53 G24

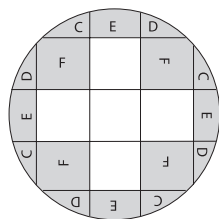

2.4m Canopy
CS ACI 44 G15
CS ACI 44 G24

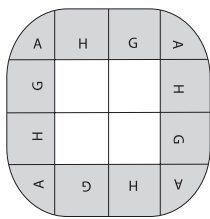

2.4m x 2.4m Canopy
CS ACU 44 G15
CS ACU 44 G24

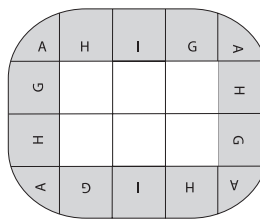

2.4m x 3m Canopy
CS ACU 54 G15
CS ACU 54 G24

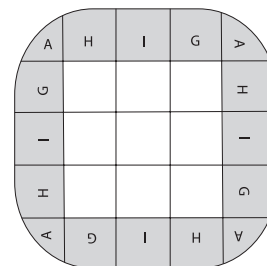

3m x 3m Canopy
CS ACU 55 G15
CS ACU 55 G24

Items needed:

12 x Standard tiles (NOT INCLUDED)

1 x Set of templates

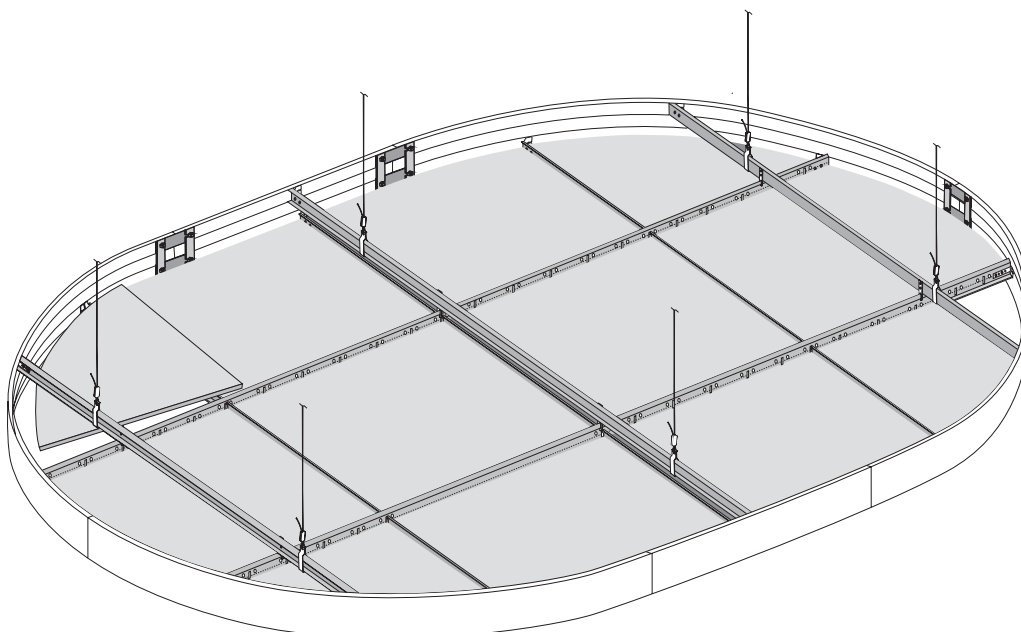

07 Physical Data

Material

- Frame: Extruded aluminium profiles
- Grid & Accessories: Hot dipped galvanised steel

Surface finish

- Frame: Polyester powder coated
- Grid capping: Baked polyester paint
- Colour: Global white

Warranty

- For more information, please see our website

14 pre-packed, ready-to-assemble Axiom Circle & Curved canopy kits, in 7 standard modules, will be available either in 15mm or 24mm grid.

Module	Grid system 15 mm XL ² Item No.	Grid system 24 mm XL ² Item No.
Circle 1800	CS ACI 33 G15	CS ACI 33 G24
Circle 2400	CS ACI 44 G15	CS ACI 44 G24
Curved 2.4 x 1.8m	CS ACU 43 G15	CS ACU 43 G24
Curved 2.4 x 2.4m	CS ACU 44 G15	CS ACU 44 G24
Curved 3 x 1.8m	CS ACU 53 G15	CS ACU 53 G24
Curved 3 x 2.4m	CS ACU 54 G15	CS ACU 54 G24
Curved 3 x 3m	CS ACU 55 G15	CS ACU 55 G24

Axiom Circle & Curved canopy kits are only available in specific markets, please contact Zentia Technical Sales. Ceiling tiles **ARE NOT** included in the kit.

Ceiling tiles are NOT included in the kit.

- Max. tile load: 10 kg/m²

For further information on customised size models please contact Zentia Technical Sales.

Advisory note:

All statements and technical information contained in this brochure, or any publication of the companies named in this brochure, relating to Zentia are based on results obtained under laboratory test conditions.

It is the responsibility of the user to verify with the seller of the products in writing that such statements and information are appropriate to the specific use intended.

Sales of the products and liability of the selling companies are in accordance with the terms and conditions of sale of the selling company.

All product specifications are subject to modifications without prior notice.

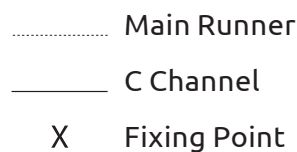
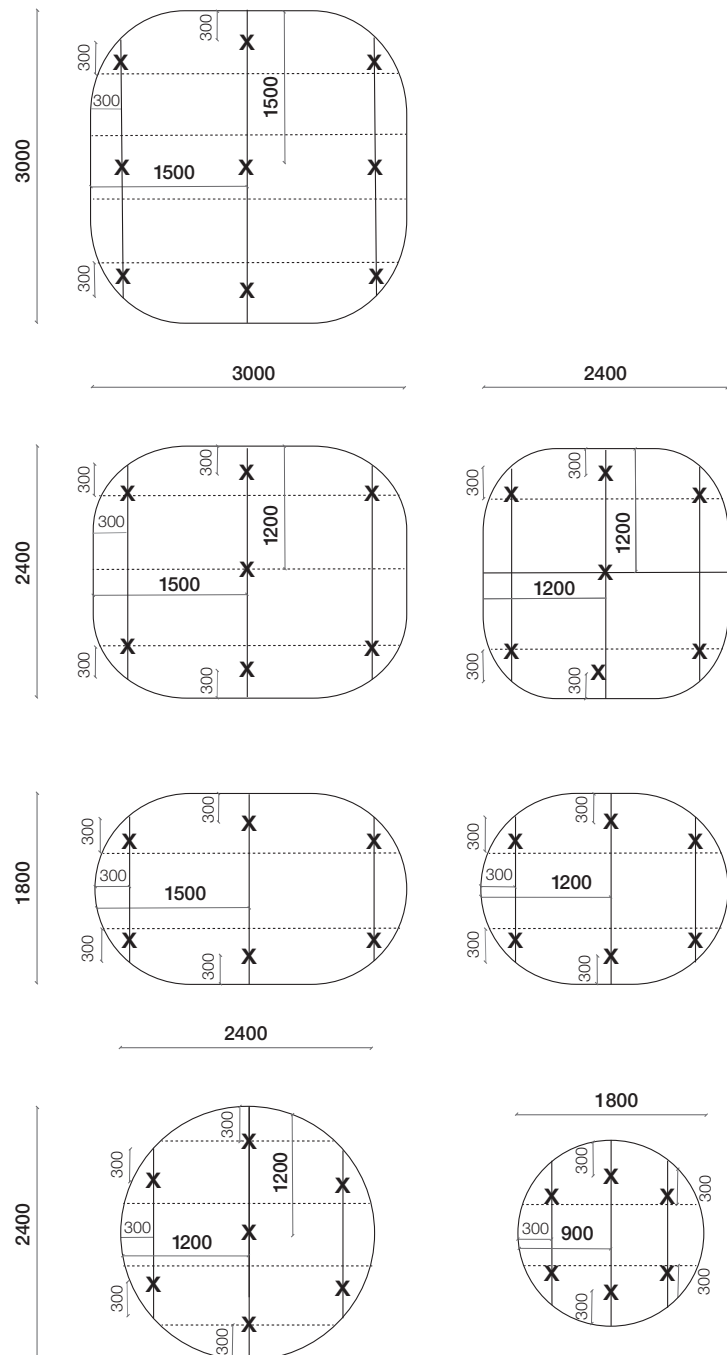







Axiom L Canopy

Installation Guide

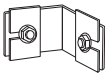

01 Preparation

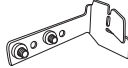
Axiom L Canopy Components

Item No.	Description
 CS 534205	Axiom L profile (78.5mm height)
 404093 G	Prelude Sixty ² main runner
 312021 A	Prelude 24 XL ² cross tee
 A 390	Mitre corner connector
 A 340 J	Axiom universal corner clip
 A 339 J	Axiom Universal T-bar connector clip
 A 347 H	Axiom 24mm XL ² connector clip

Axiom L Canopy is a modular suspension system supplied kit with ready-to-assemble components (partly listed above).

Initial Recommendations

- ✔ Axiom L Canopies should always be installed in accordance with all applicable building codes and regulations.
- ✔ Axiom L Canopies, as any other architectural feature located in the ceiling plane, may obstruct or skew the existing or planned fire sprinkler distribution pattern or even delay the activation of the fire detection system. Designers and installers are advised to consult a fire protection engineer for guidance on the proper installation techniques where fire detection or suppression systems are present.
- ✔ Any additional load (such as light spots) **MUST NOT** be suspended from the canopy but independently from the soffit.
- ✔ Axiom L Canopies should be always installed on a horizontal plane.
- ✔ Axiom L Canopies are only suitable for indoor applications.
- ✔ Axiom L Canopies can reach a significant weight. In order to minimise the risk of injuries, the canopies should be installed by a minimum of 2 people.
- ✔ Suspension elements such as threaded rods, anchors or any other element not included in the kit must be chosen to ensure a safe installation and follow local regulations.
- ✔ It is recommended to assemble the canopy under the final ceiling location to avoid later movement.

Gloves supplied in the kit are used to prevent marking the components during installation. They are **NOT** meant to be used as safety gloves.

01 Preparation

Suspension Points

Suspension points should be determined before installing the canopy.

See the recommended suspension point matrix on the last page of this guide.

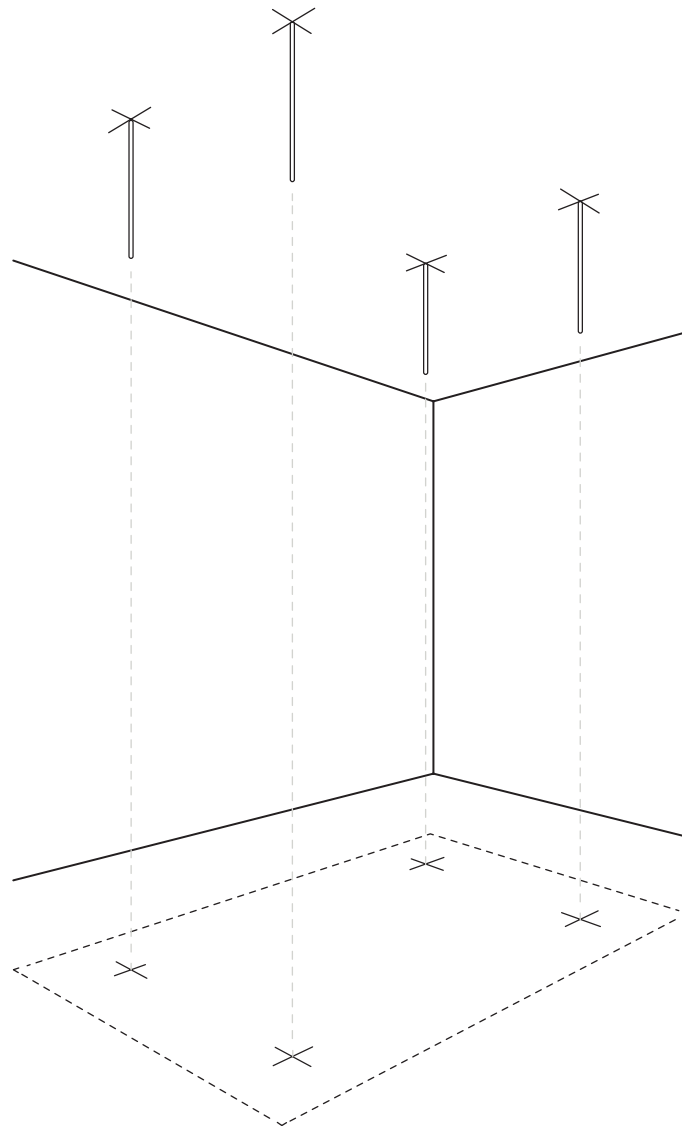

1.8 x 2.4m module



02 The Frame on the floor

Axiom L Profile

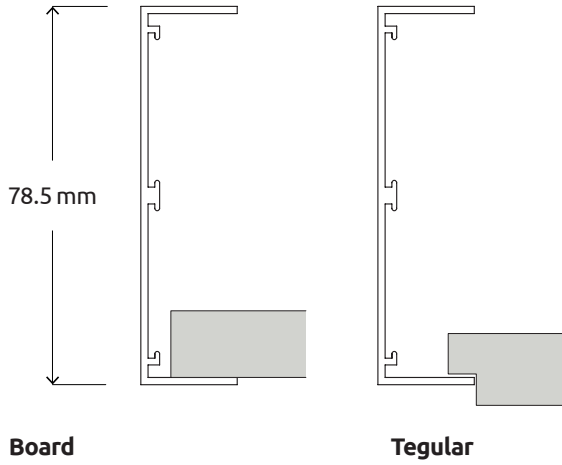

The 1.8 x 2.4m module

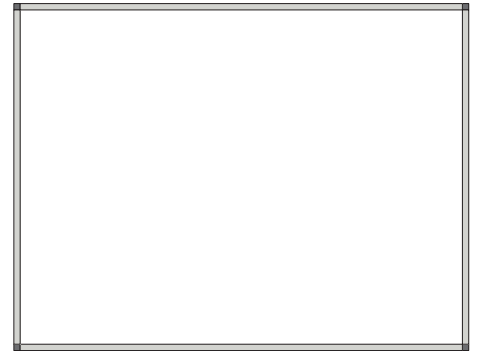

- 4 x Axiom L profiles
- 4 x Mitre corner connector A 390
- 4 x Axiom universal corner clip A 339 J

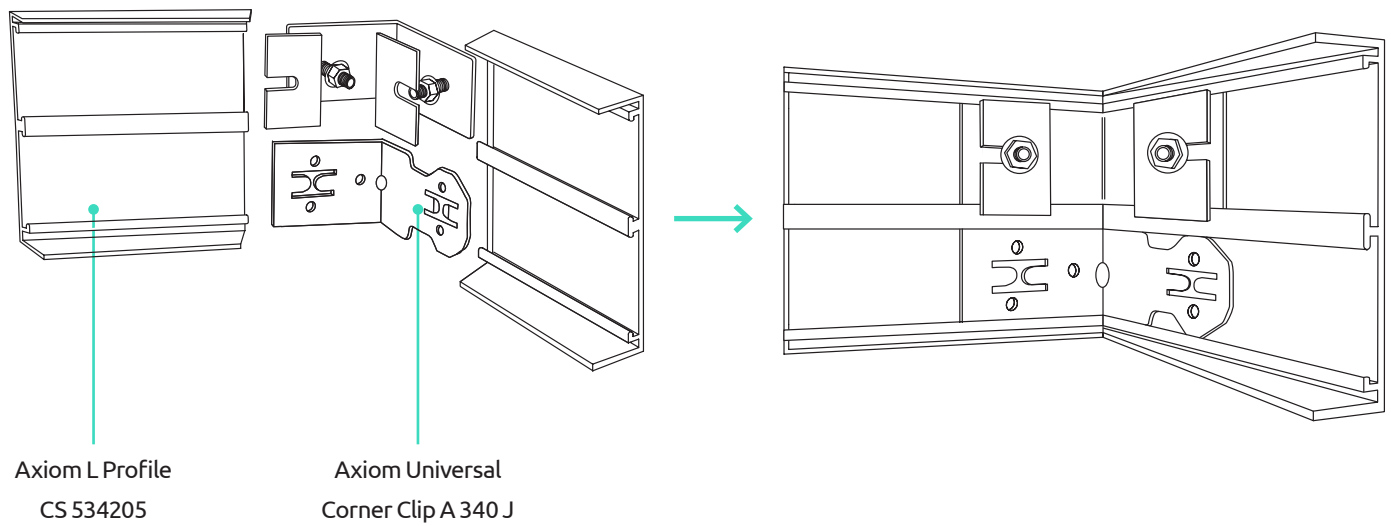

03 The Grid – Main Runner on the floor

Prelude Sixty² Main Runner

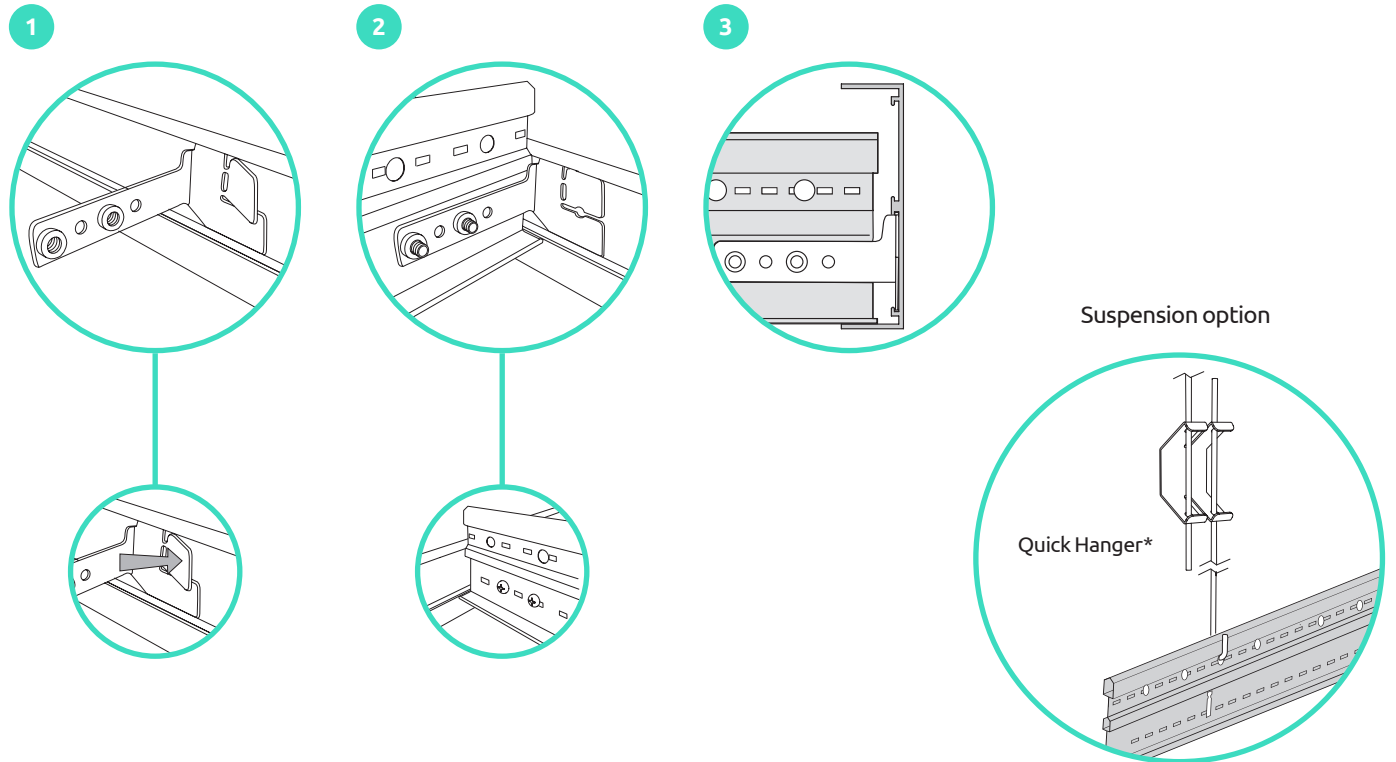
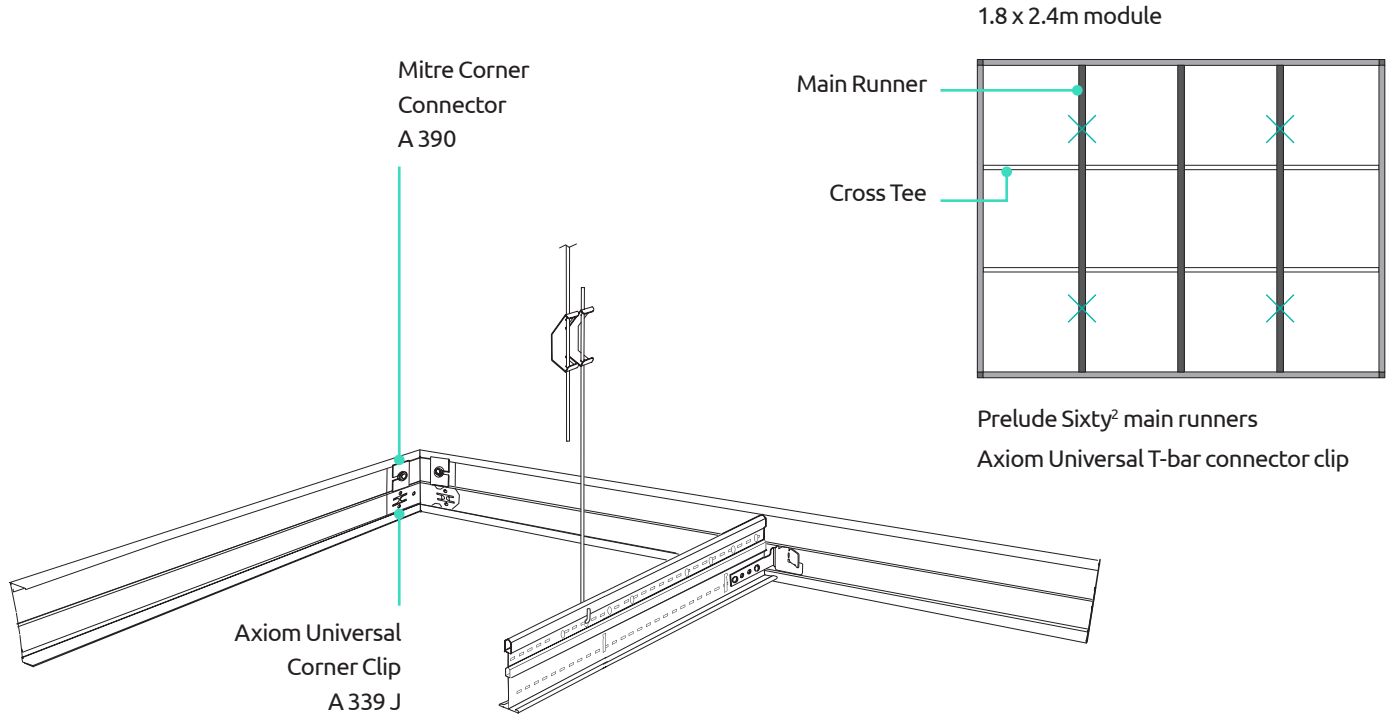

*not included in the kit.
Please contact your local Zentia office.

04 The Grid – Cross Tees

in the air

Prelude 24XL² Cross Tees

1.8 x 2.4m module

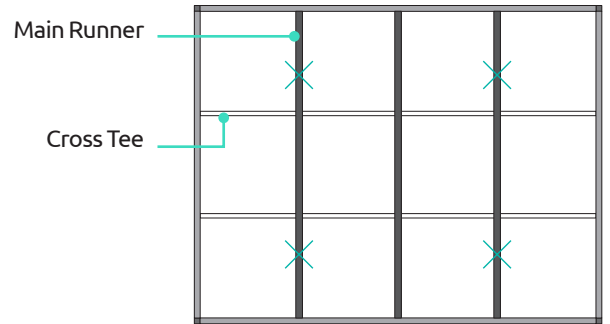

Axiom 24mm XL² connector clip
Prelude 24 XL² cross tees

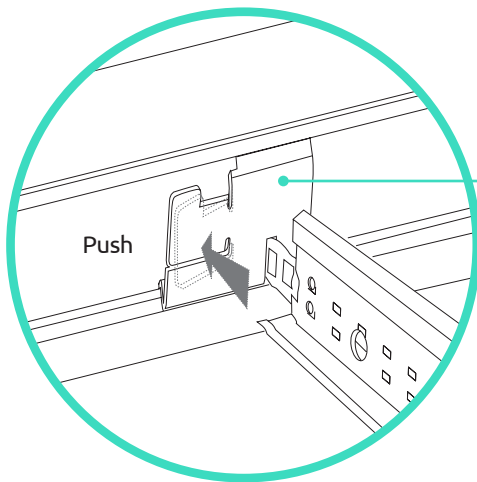

Axiom 24mm XL2 connector clip
A 347 G

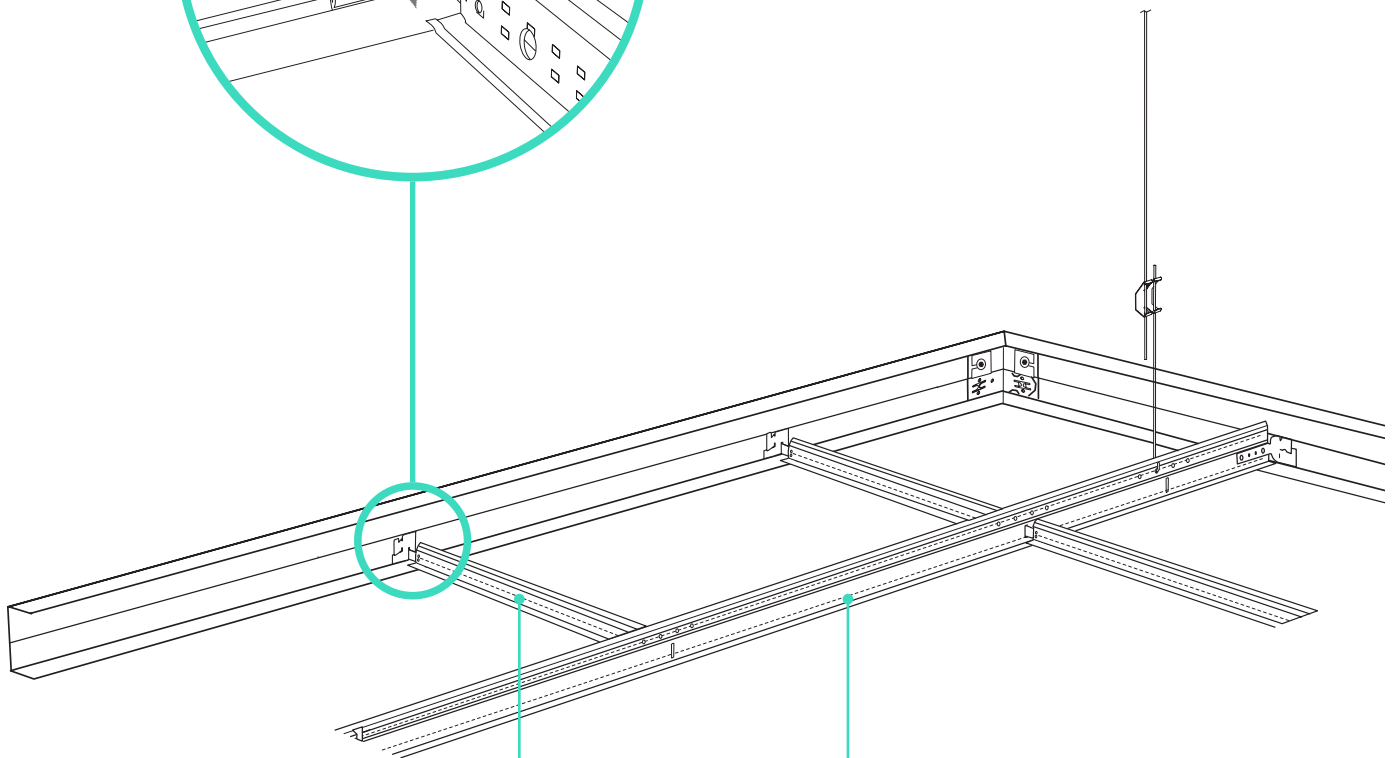

Standard 600mm
XL² cross tee
312021 A

Pre cut main runner
Prelude Sixty²
404093 G

05 The Tiles

in the air

1.8 x 2.4m module

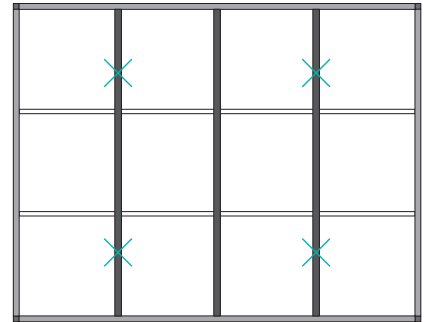

12 Tiles

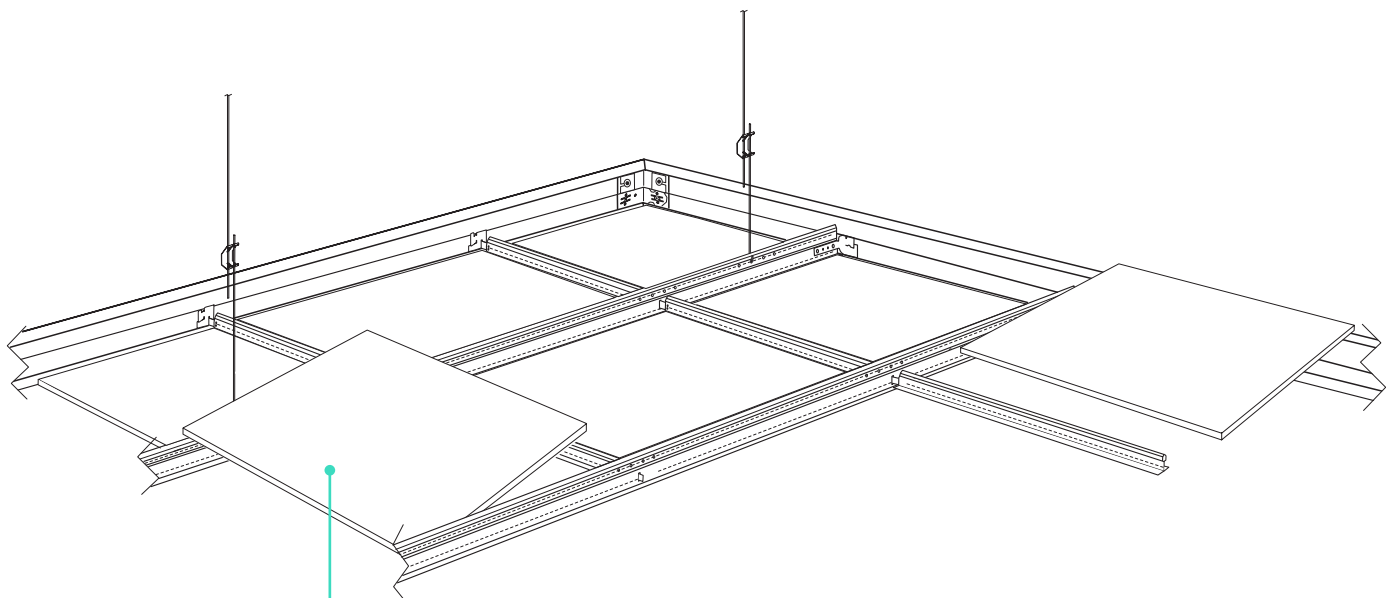
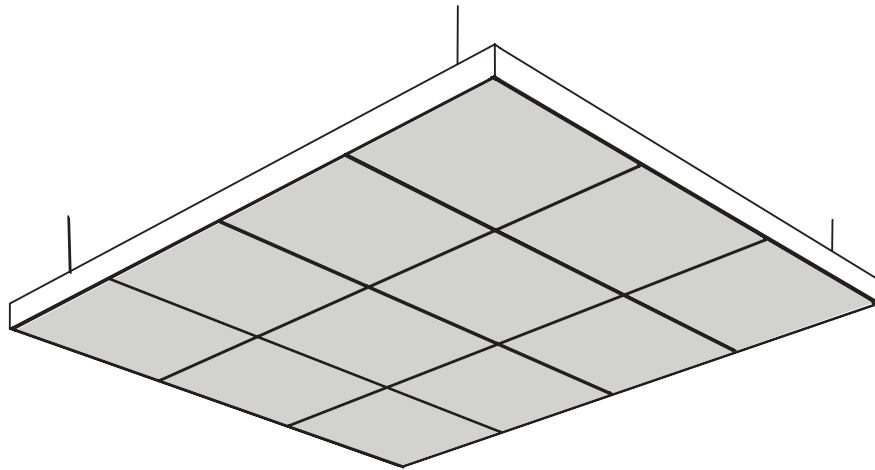

Ceiling Tile
600 x 600 mm

06 Physical Data

Material

- Extruded aluminium profiles
- Axiom L is made from extruded aluminium, offers better registration, handling capability and finished appearance compared with standard cold-rolled steel

Surface finish

- Polyester powder coated
- Global white

Warranty

- For more information, please see our website

5 pre-packed, ready-to-assemble Axiom L Canopy kits, in standard modules (metric only).

Module	Grid system 24 mm XL ² Item No.
2400 x 2400mm	CS AL 44 G24
2400 x 1800mm	CS AL 43 G24
2400 x 1200mm	CS AL 42 G24
1800 x 1800mm	CS AL 33 G24
1800 x 1200mm	CS AL 32 G24

Kits are only available in specific markets due to constraints of logistic and associated costs. Ceiling tiles are NOT included in the kit.

- Max. tile load: 5 kg/m²

For further information on customised size models please contact Zentia Technical Sales.

Advisory note:

All statements and technical information contained in this brochure, or any publication of the companies named in this brochure, relating to Zentia are based on results obtained under laboratory test conditions.

It is the responsibility of the user to verify with the seller of the products in writing that such statements and information are appropriate to the specific use intended.

Sales of the products and liability of the selling companies are in accordance with the terms and conditions of sale of the selling company.

All product specifications are subject to modifications without prior notice.

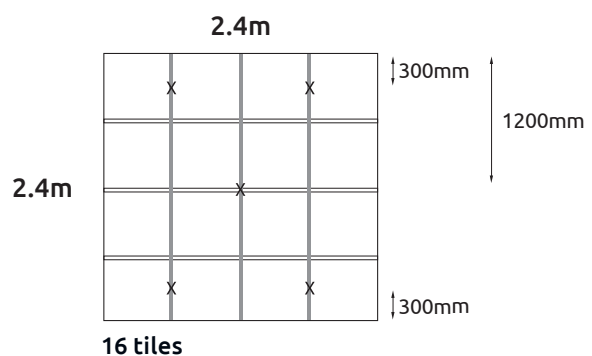
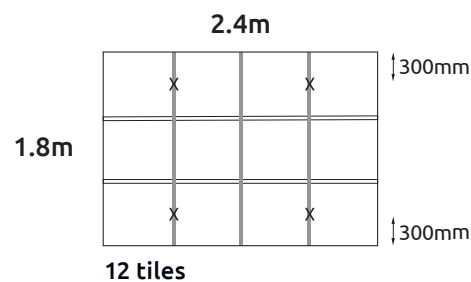
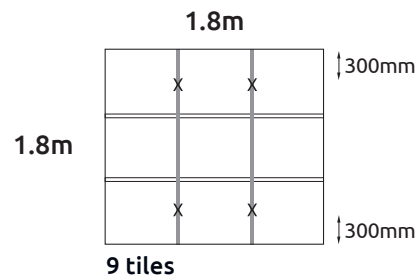
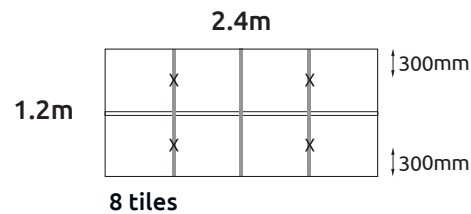
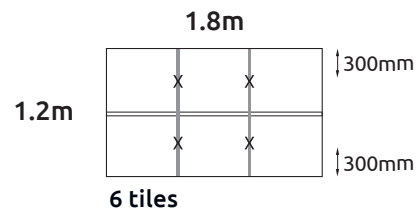

- Main Runner
- C Channel
- X Fixing Point